

Almennt:

Öll mál skulu staðfest skv. aðalteikningum. Ef eitthvert misræmi er skulu aðalteikningar vera ráðandi, þó þer að láta hönnuði vita af misræmi. Öll mál eru í millimetrum, nema annað komi fram.

Skýringar - trévirki veggja

Allur viður er C24 eða betri. Allan við utanhúss skal fúaverja. Allur saumur og festingar utanhúss skulu vera heitzinkhúðaðar eða ryðfriar. Allar stoðir og lausholt eru $4\frac{5}{145}$ nema annað sé tekið fram. Bil á milli miðjúlínu stoða skal ekki vera meira en 600 mm. Utan á grind komi 9 mm gufuorinn rakapölinn krossviður (t.d. grenikrossviður). Krossviður festist með $2\frac{8}{150}$ C150 í rakapölið lím. Þétting (Aerofil-pulsa eða lílmod þéttiborði) komi undir fótstykki, einnig skal setja vindpappa undir fótstykki, sem kemur þá á milli steypu og fótstykkis.

Festingar á öllum samskeytum:

Öll horn og einingasamskeyti skal víxlkrúfa saman með 6x80mm skrúfum c/c 400mm.

Festing á fótstykki

Múrboltar M12 C600 koma í gegnum fótstykki. Bordýpt = 105 mm og snertidýpt bolta við steyptan flöt => 80 mm.

F1 - F6
sjá sérmyndir.

Öll mál eru í millimetrum, nema annað sé tekið fram.

Br: Breyting Dags: Samp:

VERKHEITI: Brekkuholt 8a-d 806 Selfoss	TEKNI-NÚMÉR: 203
VERKHLUTI: Burðarvirki Ásýnd grindur	ÚTGÁFA: A1
Hönnuður: Leifur Örn Leifsson kt. 150982-4139 Yfirfarið af hönnunarstjóra: Bent Larsen kt.141177-3469	Sambýkt: <i>[Signature]</i> Sambýkt: <i>[Signature]</i>
BLADSTÆRÐ: A-2	DAGS: 24.03.21
LARSEN HÖNNUN OG RADGJÖF	Bent Larsen Fróðason Byggingarfræðingur B.Sc. Sími 844-7699 tölvupóstur: bent@larsenhr.is
VERKNR: 20-88	MKV: 1-50

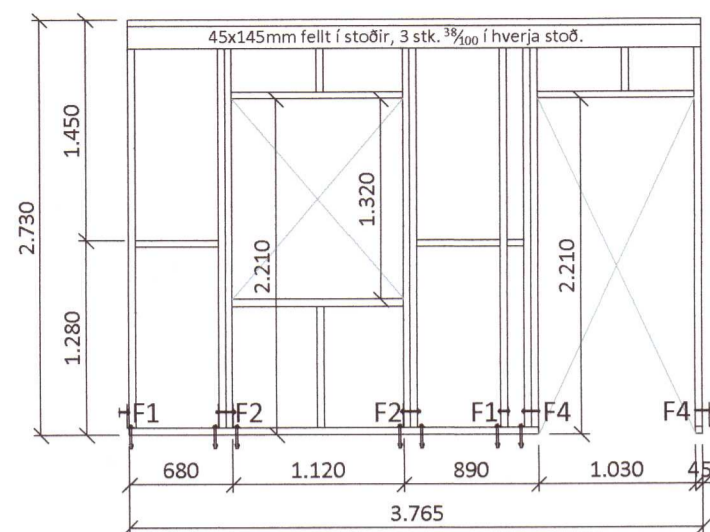

Grind nr. 19

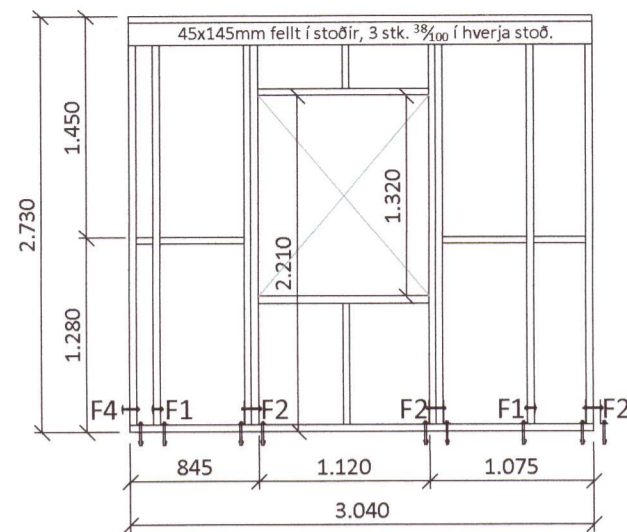

Grind nr. 18

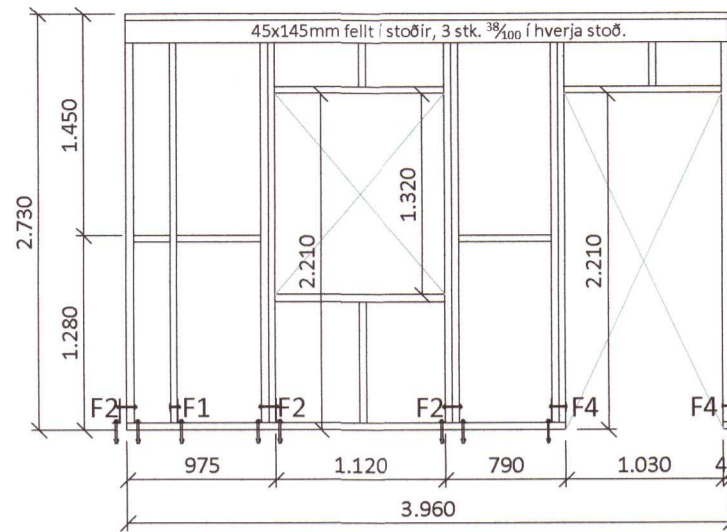

Grind nr. 17

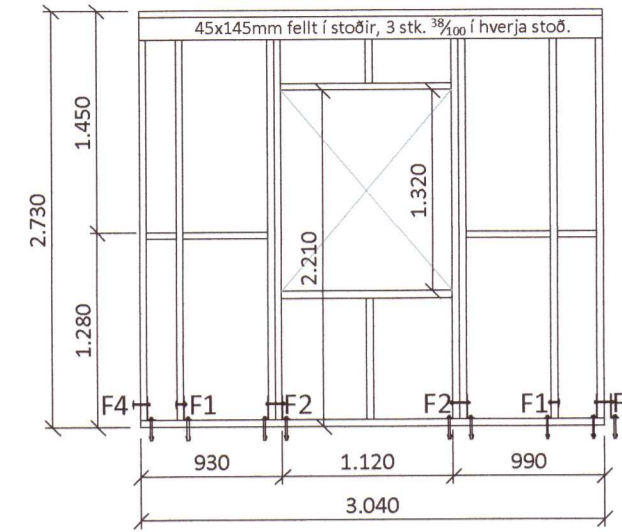

Grind nr. 16

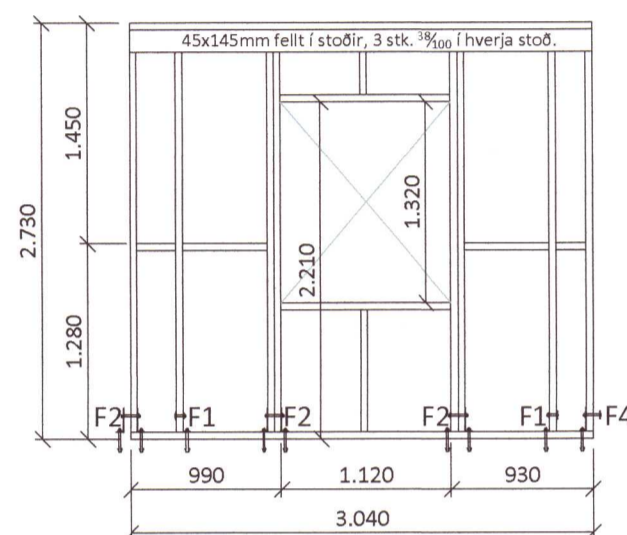

Grind nr. 15

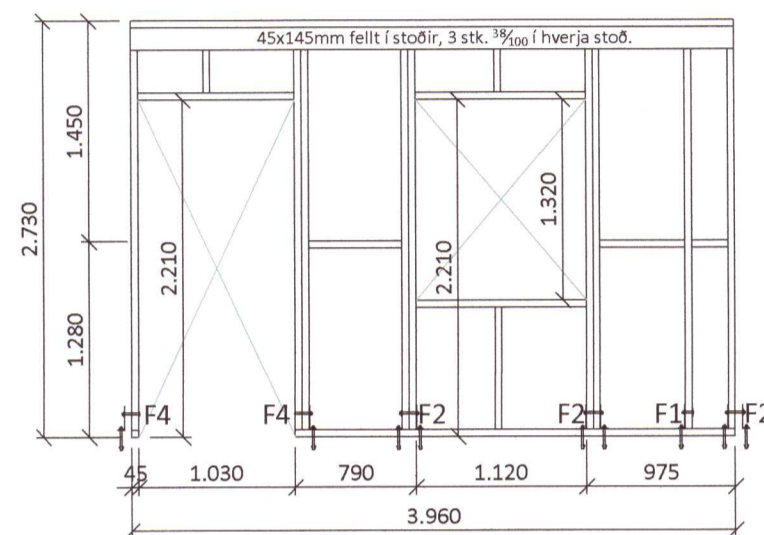

Grind nr. 14

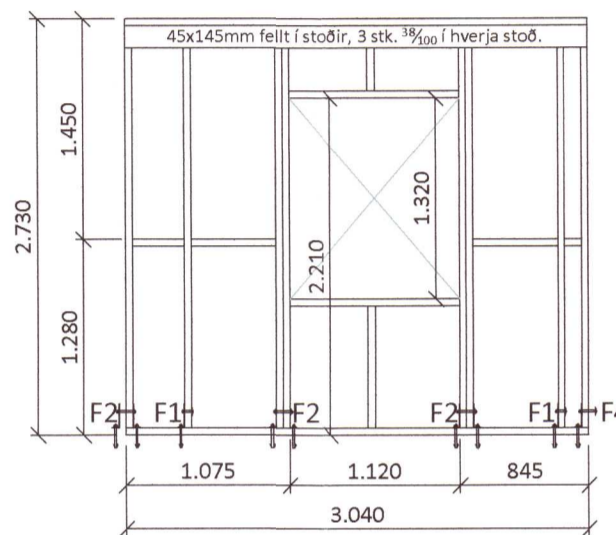

Grind nr. 13

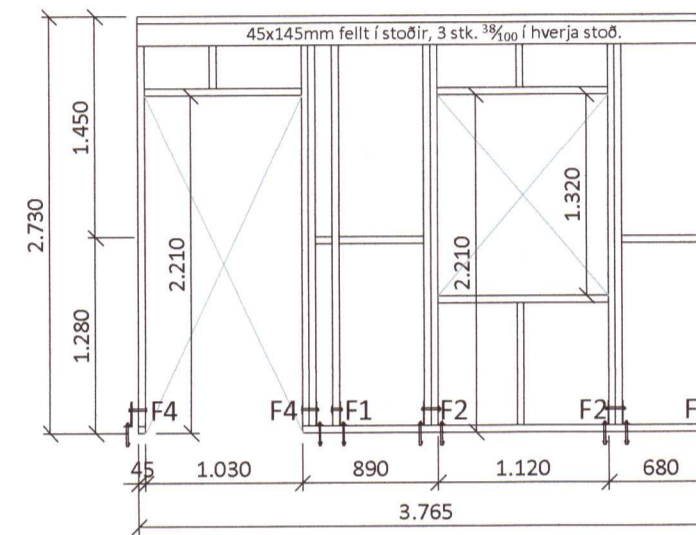

Grind nr. 12

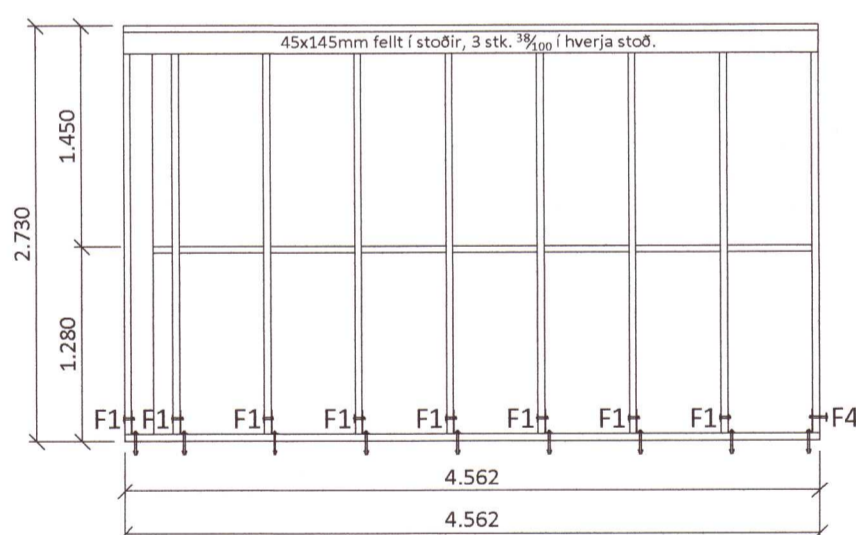

Grind nr. 11

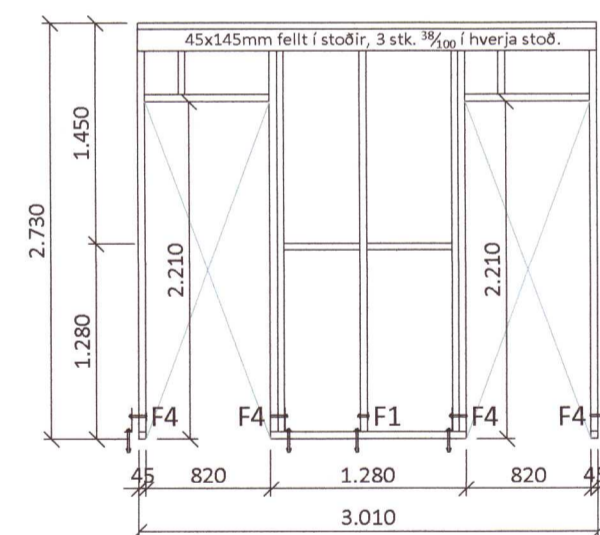

Grind nr. 10

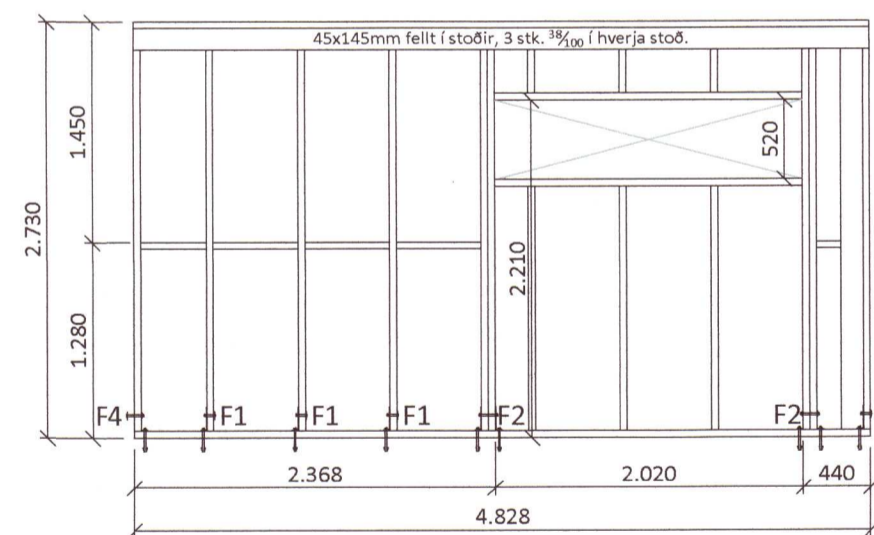

Grind nr. 9

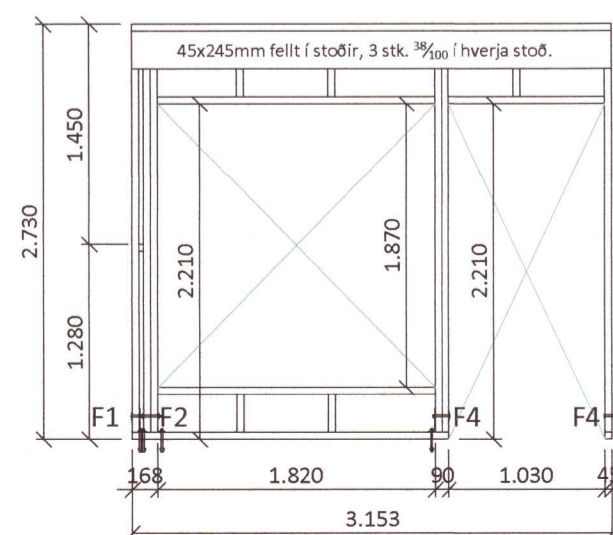

Grind nr. 8

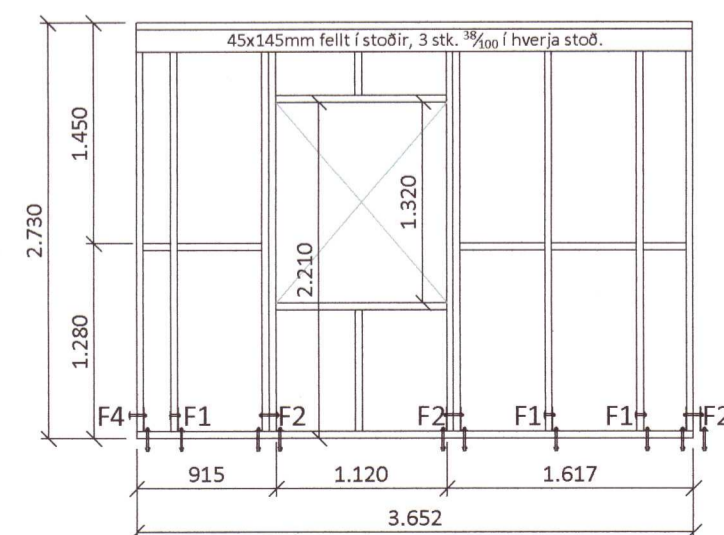

Grind nr. 7

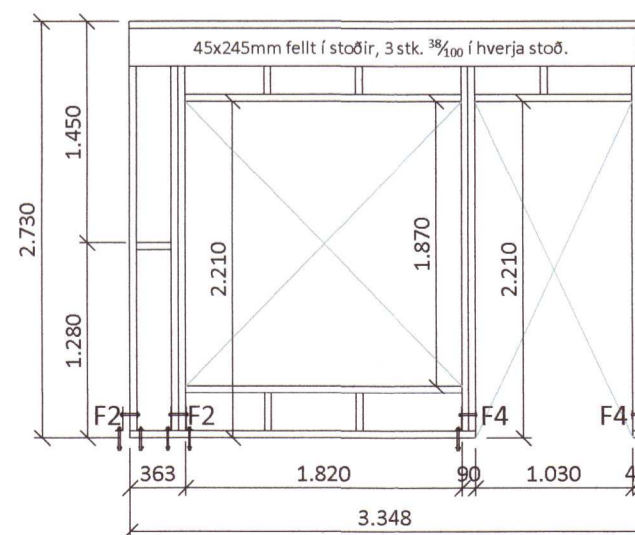

Grind nr. 6

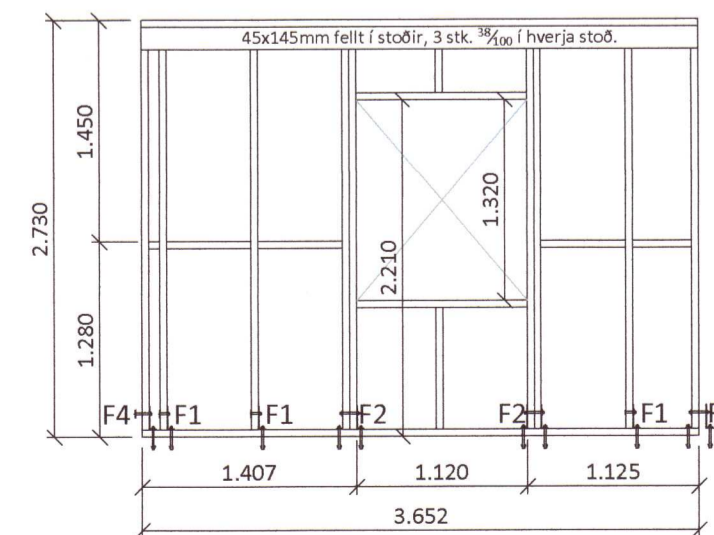

Grind nr. 5

20211098