

Grind nr. 13

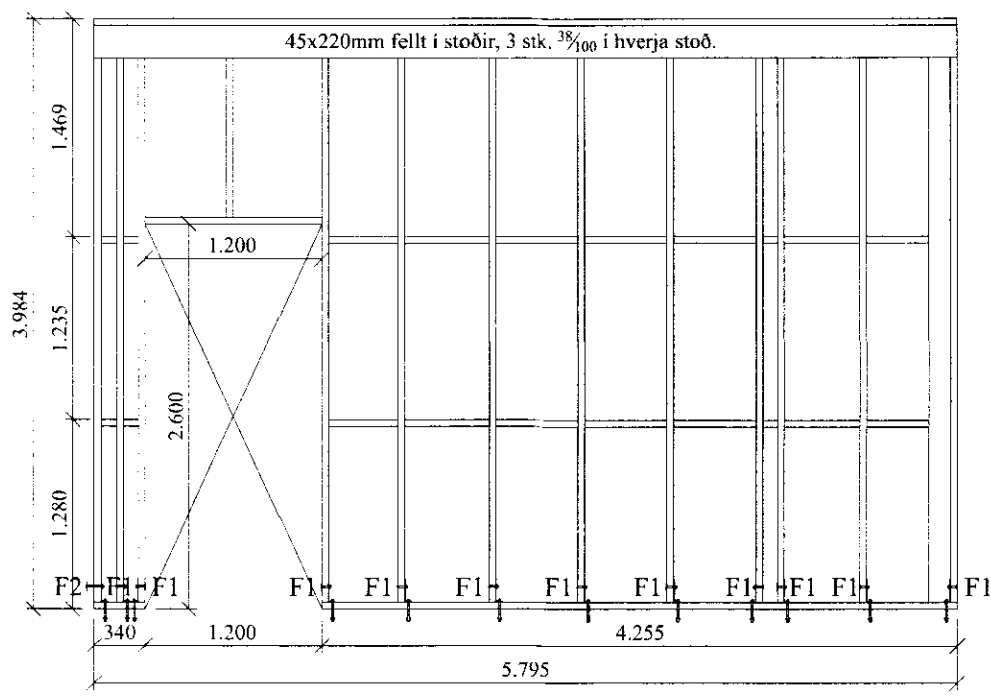

Grind nr. 5

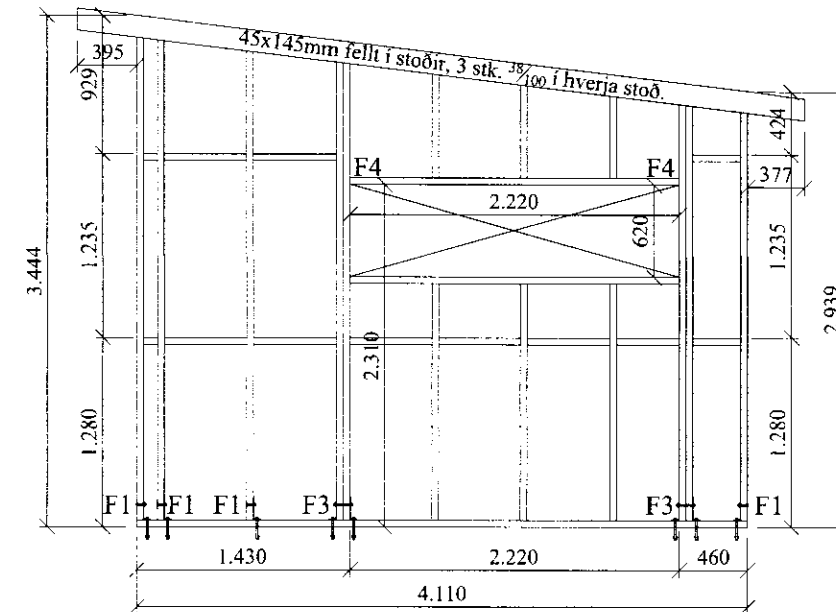

Grind nr. 18

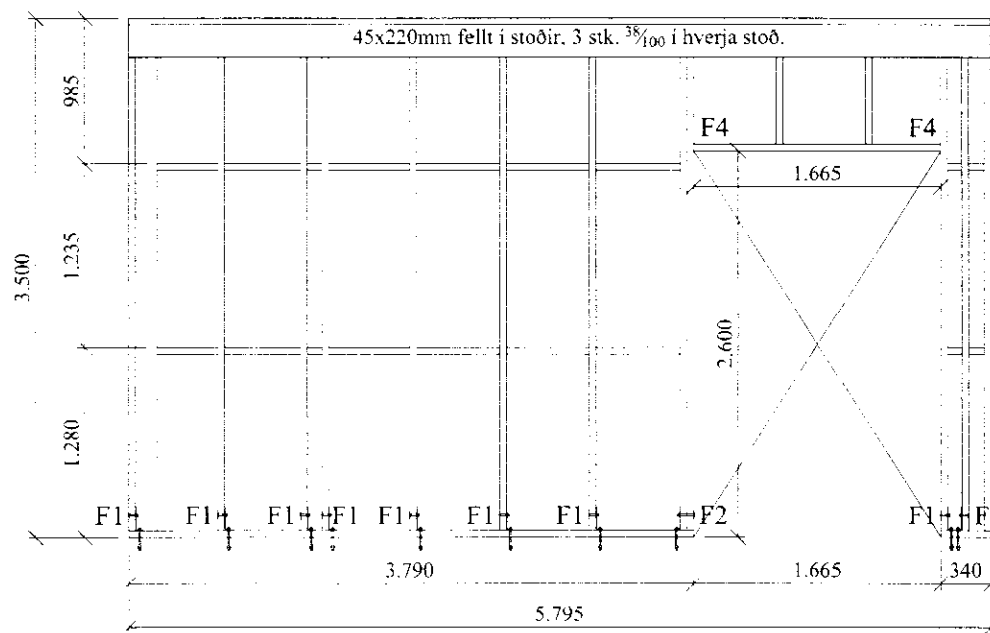

Grind nr. 3

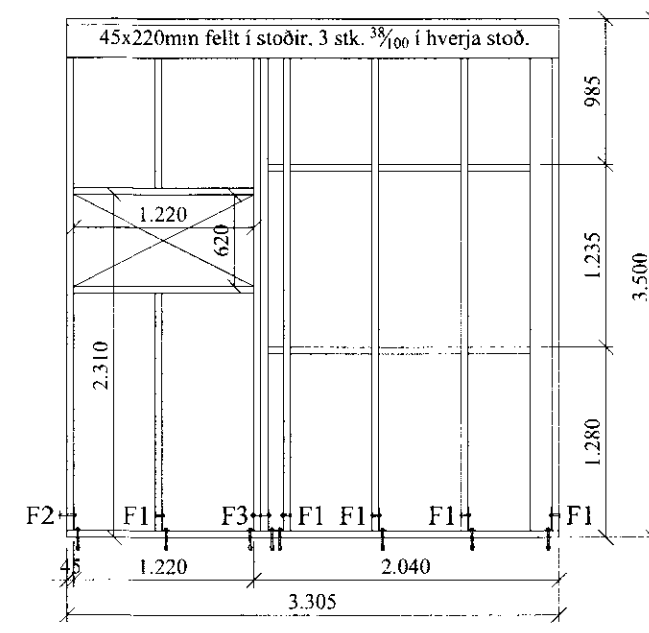

Grind nr. 15

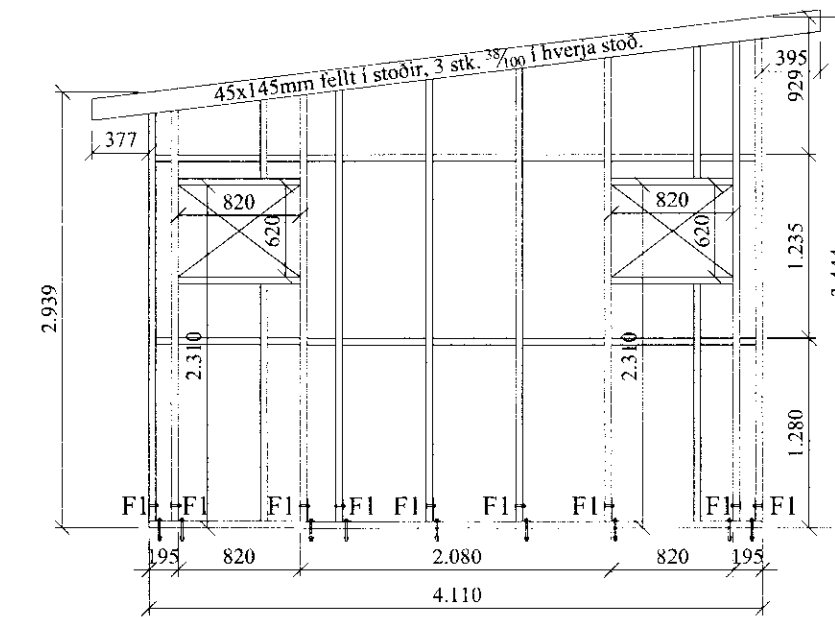

Grind nr. 9

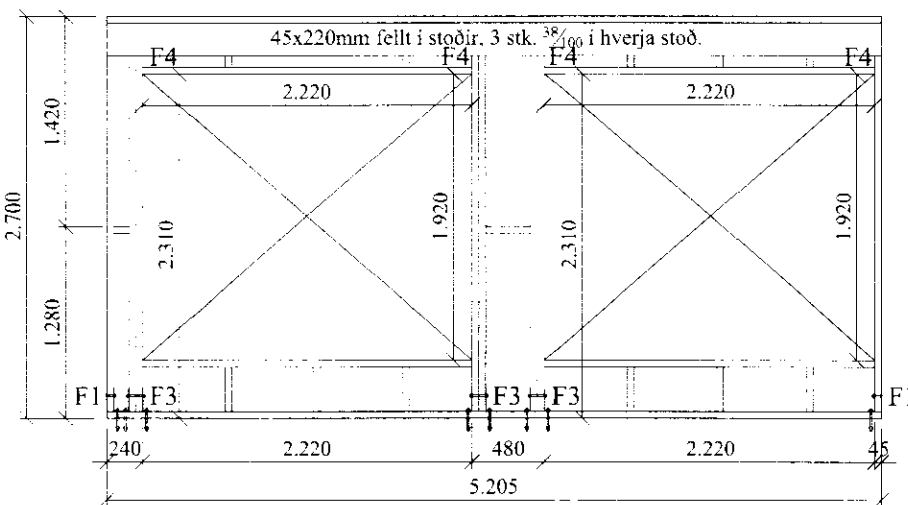

Grind nr. 12

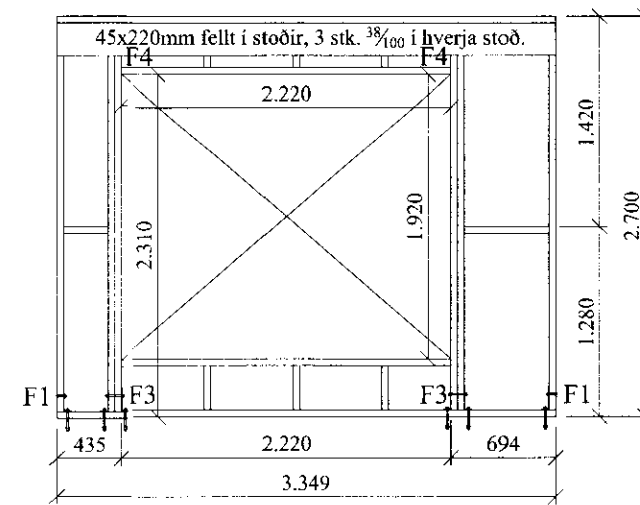

Grind nr. 11

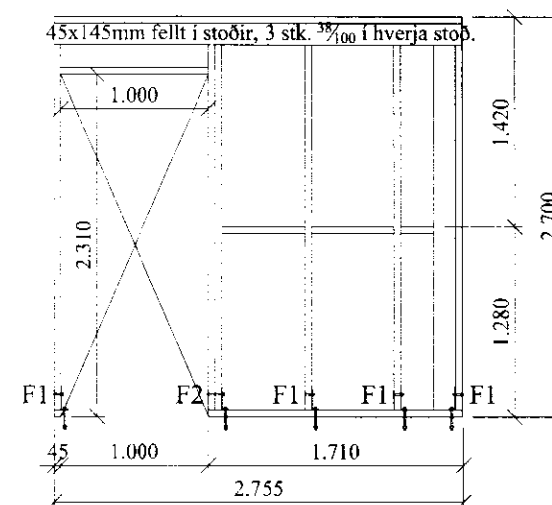

Grind nr. 10

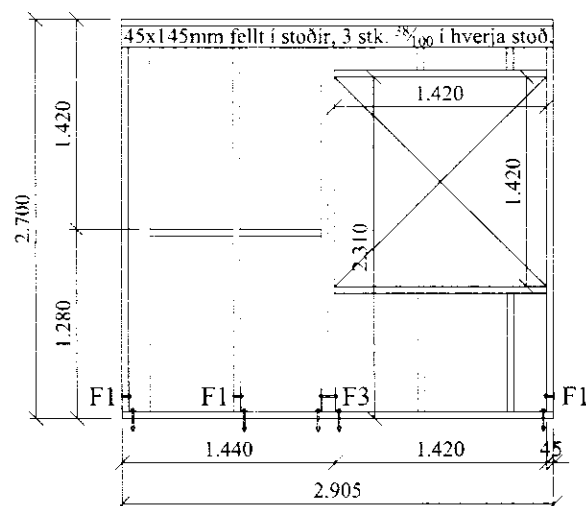

Grind nr. 17

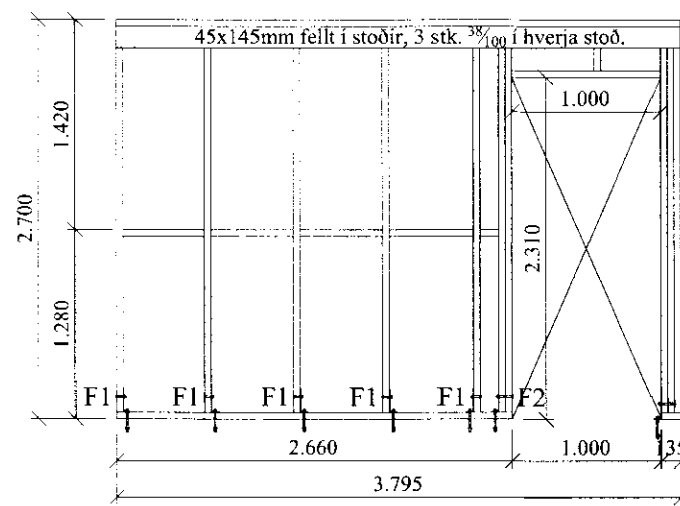

Grind nr. 16

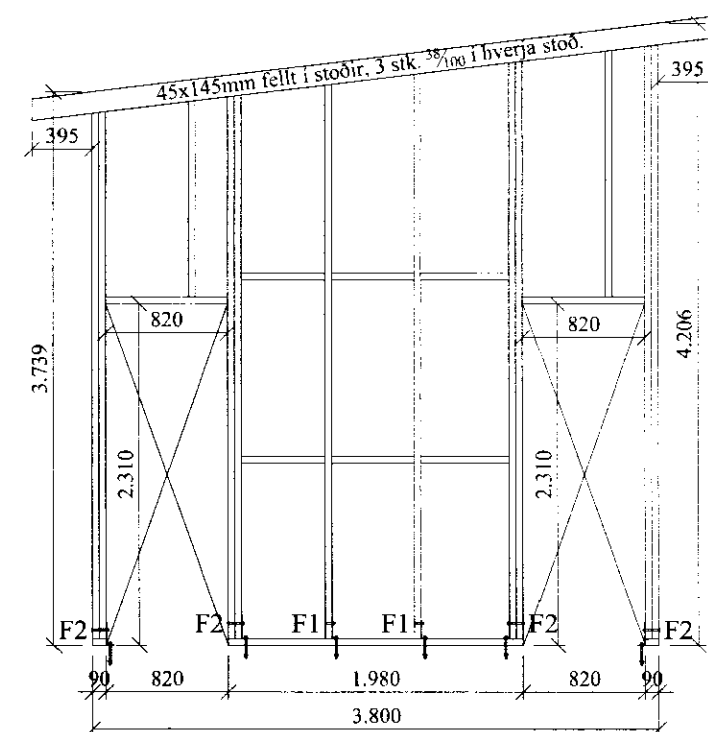

Grind nr. 14

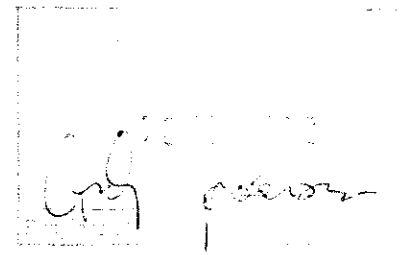

Almennt:

Öll mál skulu staðfest skv. aðaltekningum. Ef eitthvert misræmi er skulu aðaltekningar vera ráðandi, þó ber að láta hönnuði vita af misræmi. Öll mál eru í millimetrum, nema annað komi fram.

Skýringar - trévirki veggja

Allur viður er K18 eða betri skv. DS413. Allan við utanhúss skal fúaverja. Allur saumur og festingar utanhúss skulu vera heitzinkhúðaðar eða ryðfríar. Allar stoðir og lausholt eru $\frac{48}{148}$ nema annað sé tekið fram. Bil á milli miðjúlínu stoða skal ekki vera meira en 600 mm. Utan á grind komi 9 mm gufuopinn rakapólinn krossviður (t.d. birkikrossviður). Krossviður festist með $\frac{2}{65}$ C150 í rakapólið lím. Þétting (Aerofil-púlsa eða Illmod þéttborði) komi undir fótstycki.

Festingar á öllum samskeytum:

Saumur $\frac{38}{100}$ minnst 2x2 stk. skáneglist í kross í hver samskeyti.

Festing á fótstycki

Múrboltar M12 C400 koma í gegnum fótstycki. Bordýpt = 95 mm og snertidýpt bolta við steypnan flöt => 80 mm. Tvöfaldir eða þrefaldir stoðir boltast saman með 10 mm boltum c200, með 50 mm fjarlægð frá miðlínu stoðar, á vixl.

F1-F4

Sjá sémyndir

VERK:	Grjóthólsbraut nr. 10 - Öndverðanesi, 801 Grímsnes	TEIKN NR.:	201
HLUTI:	Burðarvirki Ásýnd grindur	KVARDI:	1:50
DAGS:	11.06.12	TEIKN:	BL
SAMF.:	Björgvin Viglundsson 040546-2009	NR.:	01 115
Bent Larsen Fróðason Fells koti 2 801 Bláskógabyggð Símar: 844-7699 - 486-8855 E-mail: bentlarsen77@hotmail.com			