

MÓTTEKIÐ

04 SEPT. 2008

Byggingafráttir uppáv. Árnæssýslu og Flóah. *Jul*

U0 1:20

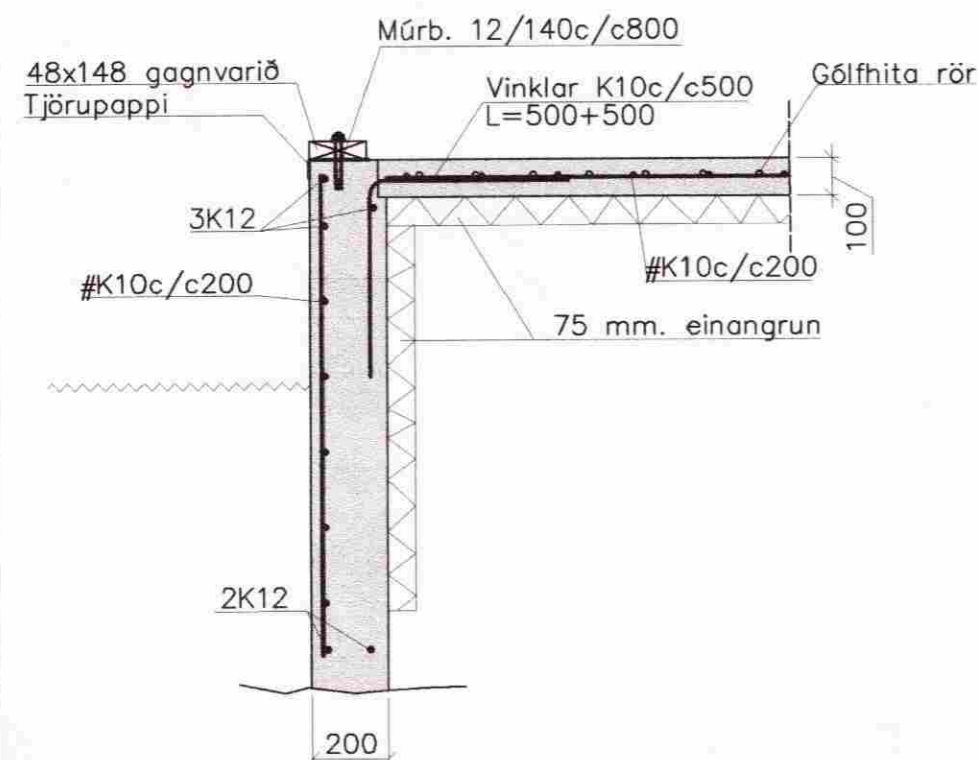

U00 1:20

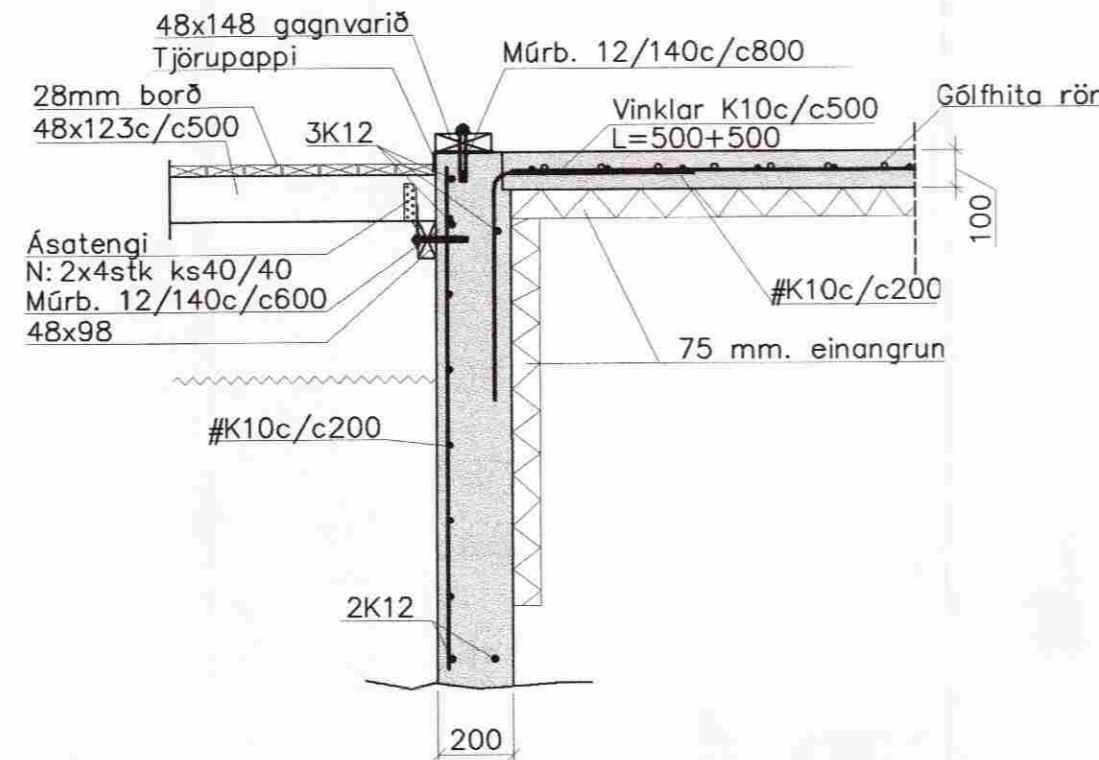

U1 1:20

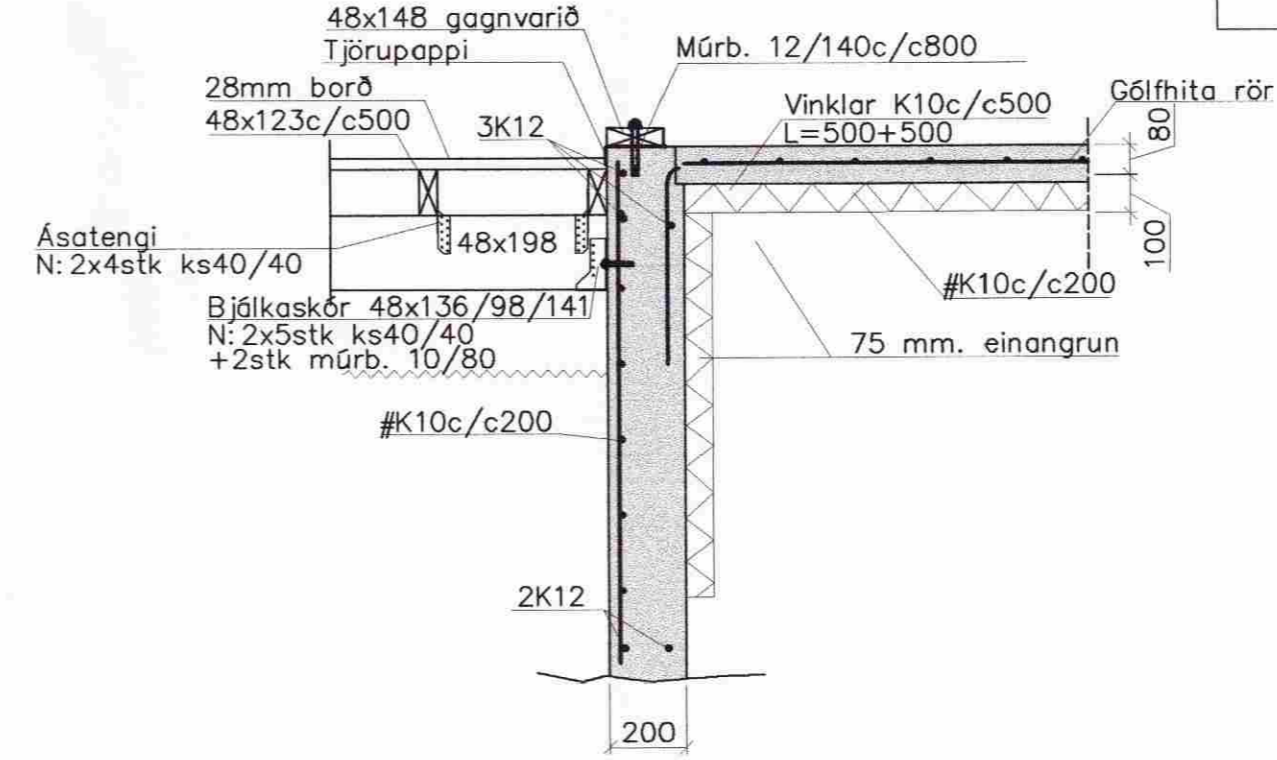

U2 1:20

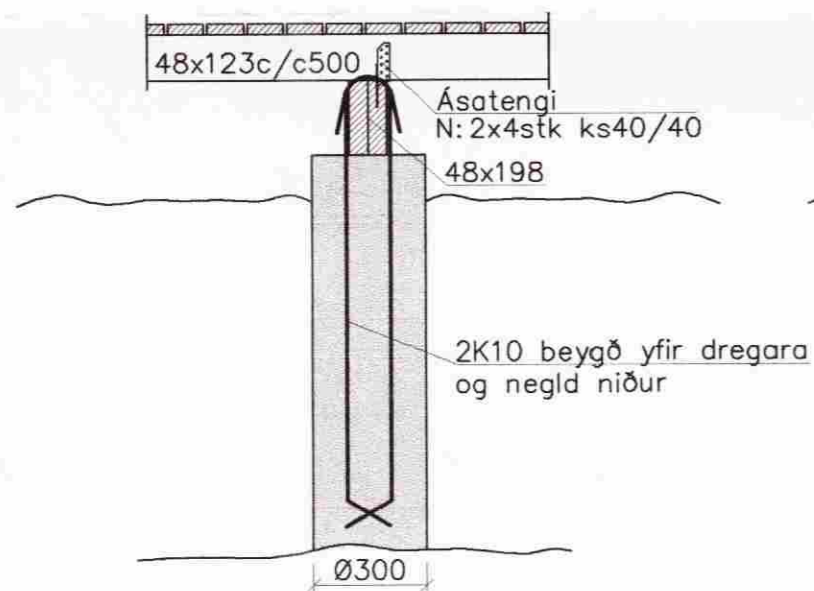

U3 1:20

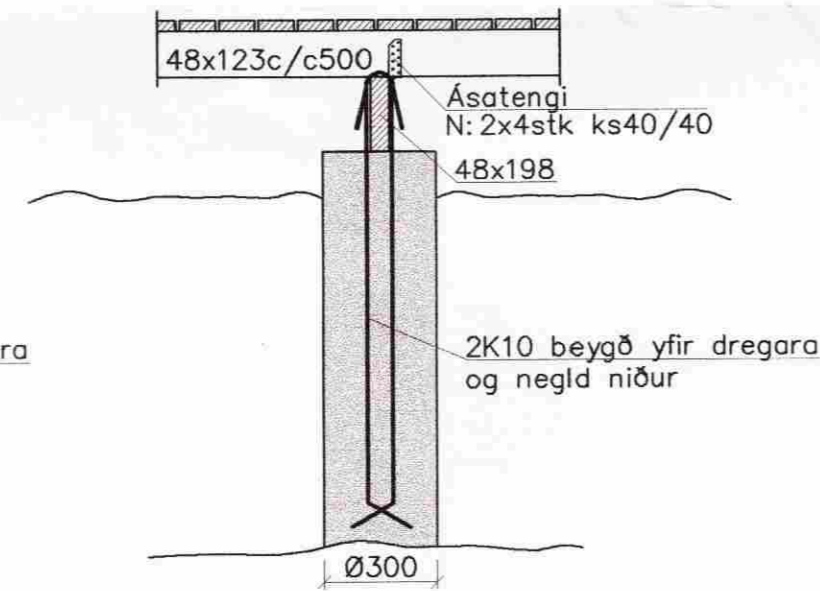

U4 1:20

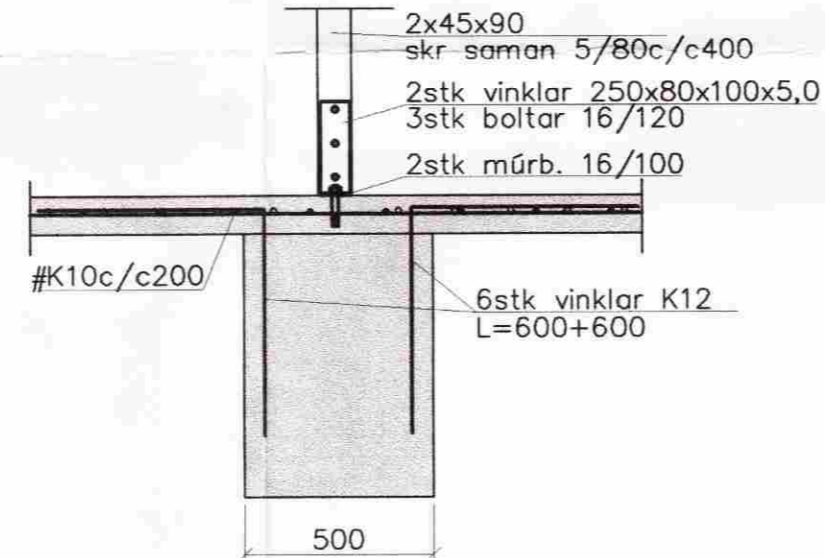

U5 1:20

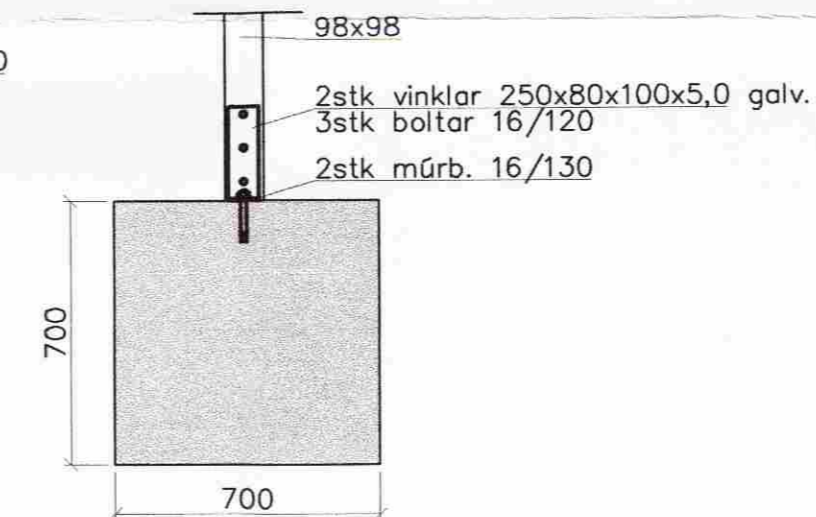

Steypa C25
Sement > 300 kg/m³, vatnssementstala v/s < 0.55,
loftinnihald 5-6%, sigmál 80-100 mm.
Steypa og steypustyrktarstál B500C skv. ÍST-14/DS-411.
Steypuhula á jærnum í steypu í jörð minnst 30 mm.
Hönnun og framkvæmd verksins skal í samræmi við
gildandi staðla og reglugerðir.
Undirstöður á hraun fyllingu, mesta álag 4kg/cm²
Notálag á gólf 250 kg/m²

Breytingar			Oddsholt 34 sumarhús	
Nr.	Dags.	Nafn	H	BS T HS S
			M	1:20
			Nr.	B002
			Dags.	Ágúst 08
				080149-3609
				090638-4839
				<i>Jul</i>

Samf. Jón Guðmundsson