

Grind nr. 1

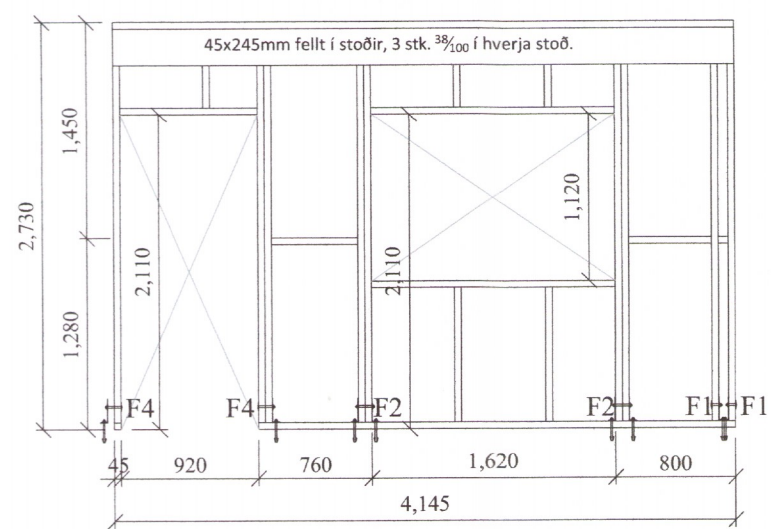

Grind nr. 2

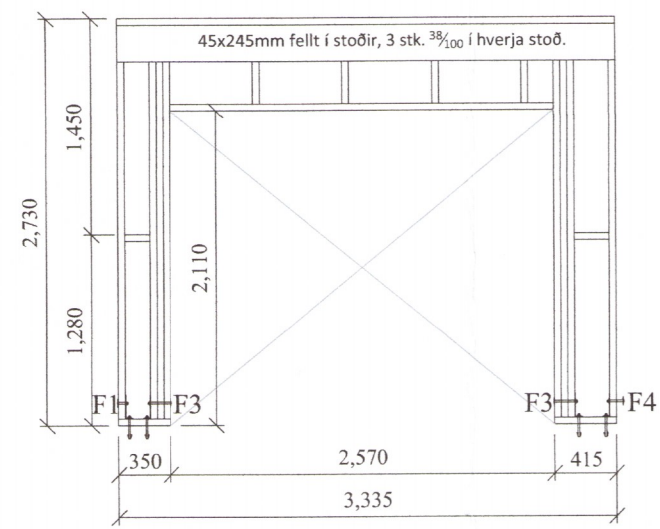

Grind nr. 3

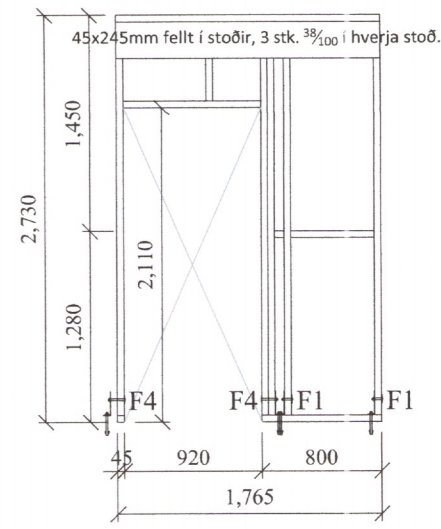

Grind nr. 4

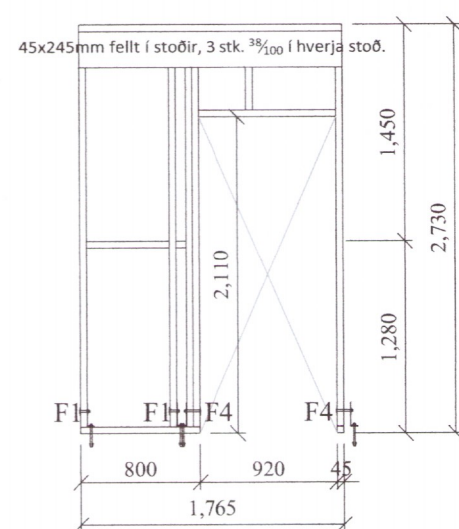

Grind nr. 5

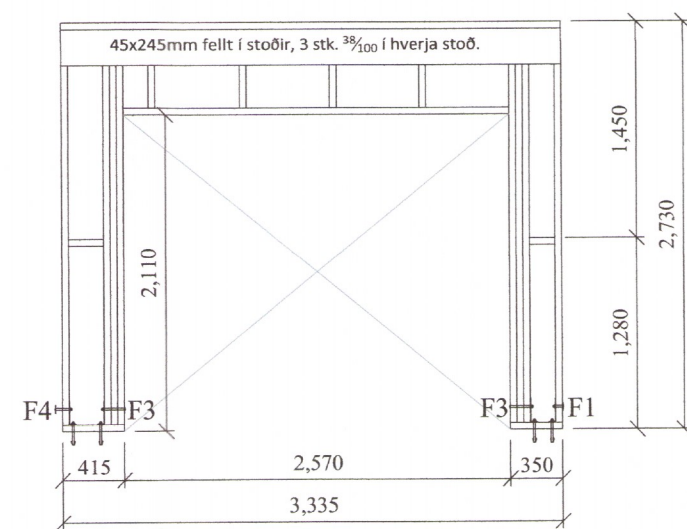

Grind nr. 6

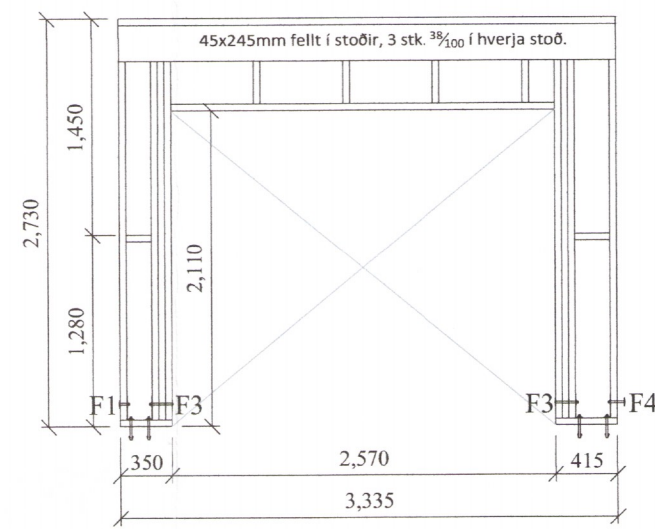

Grind nr. 7

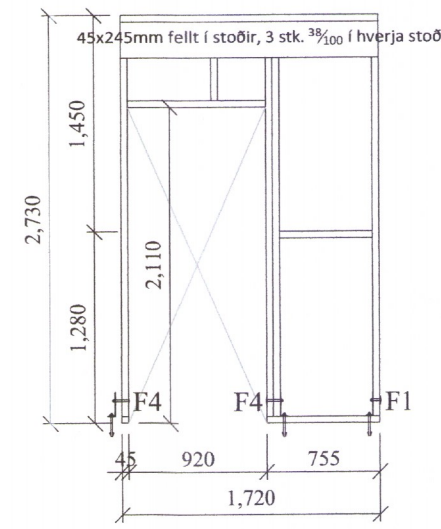

Grind nr. 8

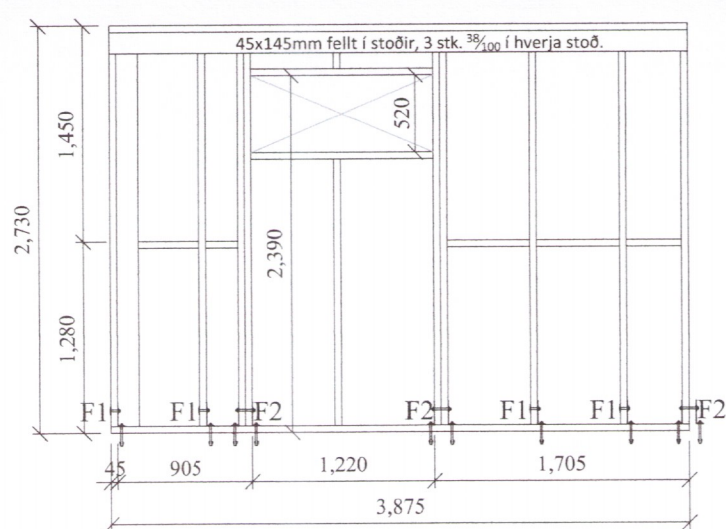

Grind nr. 9

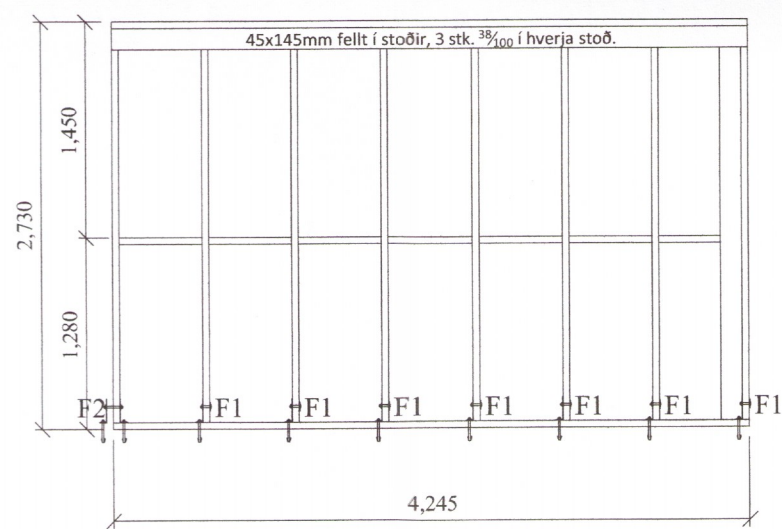

Grind nr. 10

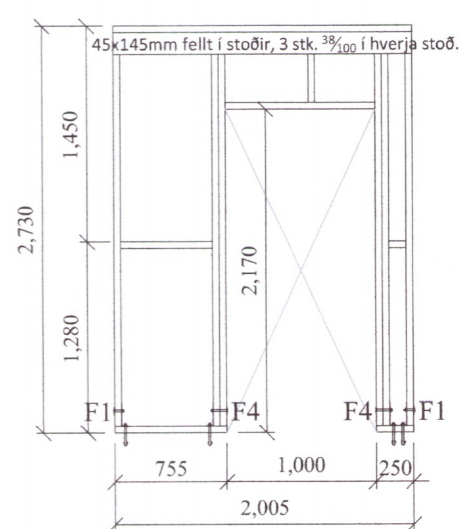

Grind nr. 11

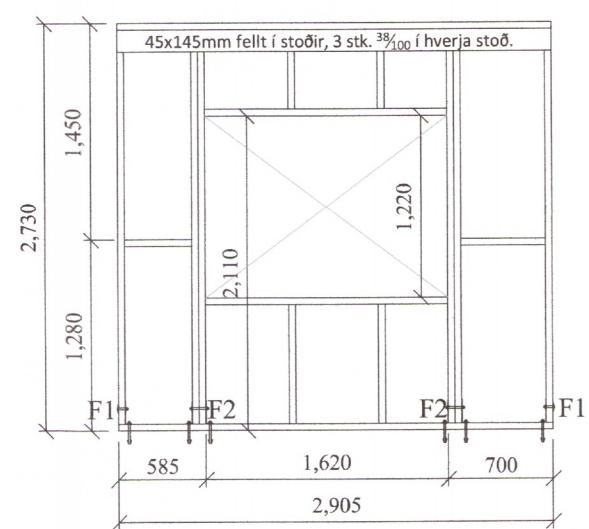

Grind nr. 13

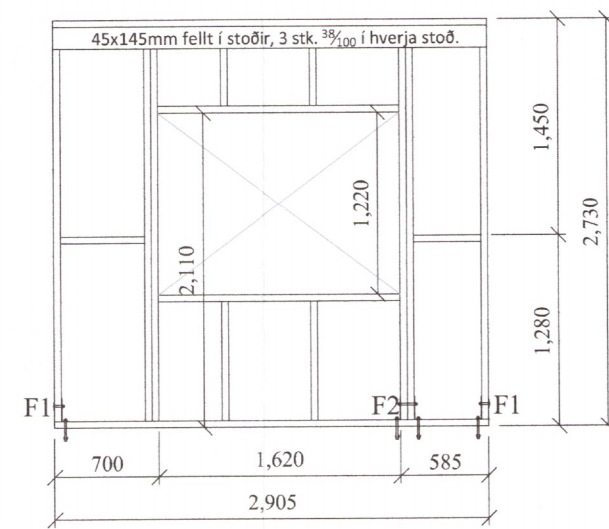

Grind nr. 14

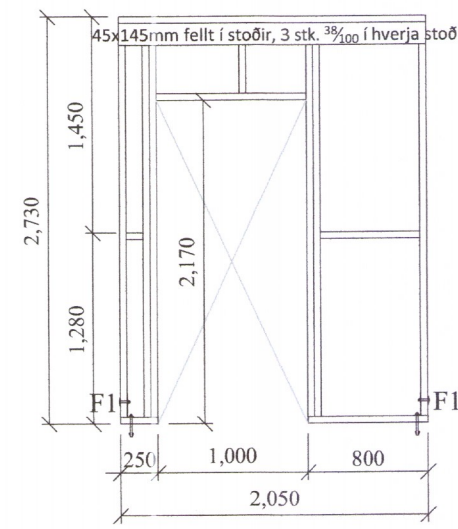

Grind nr. 16

Almennt:

Öll mál skulu staðfest skv. aðalteikningum. Ef eitthvert misræmi er skulu aðalteikningar vera ráðandi, þó þer að láta hönnuði vita af misræmi. Öll mál eru í millimetrum, nema annað komi fram.

Skýringar - trévirki veggja

Allur viður er C24 eða betri. Allan við utanhúss skal fúaverja. Allur saumur og festingar utanhúss skulu vera heitzinkhúðaðar eða ryðfriar. Allar stoðir og lausholt eru $4\frac{1}{2}$ nema annað sé tekið fram. Bil á milli miðjulinu stoða skal ekki vera meira en 600 mm. Utan á grind komi 9 mm gufuopinn rakabollinn krossviður (t.d. grenikrossviður). Krossviður festist með $2\frac{3}{16}$ C150 í rakapolið lím. Þétting (Aerofil-pulsa eða Illmod þéttiborði) komi undir fótstykki, einnig skal setja vindpappa undir fótstykki, sem kemur þá á milli steypu og fótstykkis.

Festingar á öllum samskeytum:

Öll horn og einingasamskeyti skal víxlskrúfa saman með 6x80mm skrúfum c/c 400mm.

Festing á fótstykki

Múrboltar M12 C600 koma í gegnum fótstykki. Borddypt = 105 mm og snertidypt bolta við steypnan flöt => 80 mm.

F1 - F4 sjá sérmyndir.

Öll mál eru í millimetrum, nema annað sé tekið fram.

Br: Breyting Dags: Samþ:

| | |
|--|---------------------|
| VERKHEITI: Friðheimar 6-9, St.mannahús 801 Bláskógabyggð | TEIKNINÚMÉR: 203 |
| VERKHLUTI: Búðarvirki Ásýnd grindur | ÚTGÁFA: A1 |
| Hönnuður: Leifur Örn Leifsson kt. 150982-4139 | BLADSTJÓRD: A-2 |
| Yfirfarið af hönnunarstjórn: Reynir Adamsson kt. 240448-2469 | DAGS: 11.02.19 |
| Sambýtt: <i>Sigurður S. Haf</i> Sambýtt: <i>Bent Larsen</i> Bent Larsen Fróðason Byggingarfræðingur B.Sc Sími 844-7699 tölvupóstur: bent@larsenr.is | |
| LARSEN HÖNNUN OG RÁÐGJÖF | |
| VERKNR: 18-62 | MKV: 1:50 |

1666-19