

Grind nr. 1

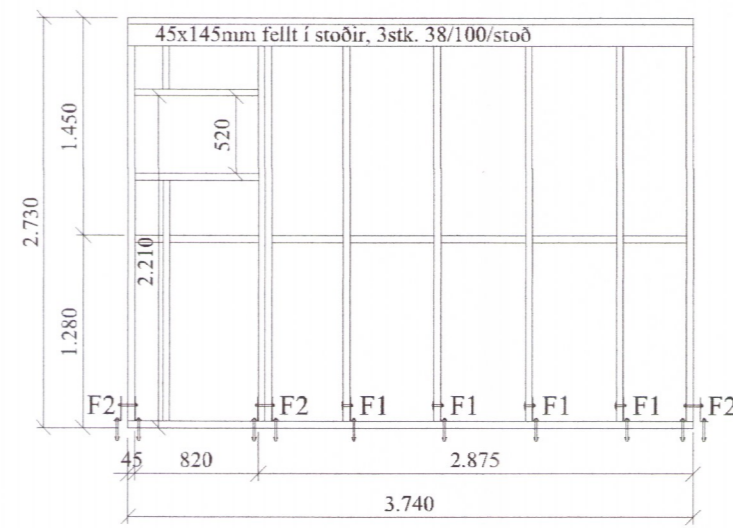

Grind nr. 2

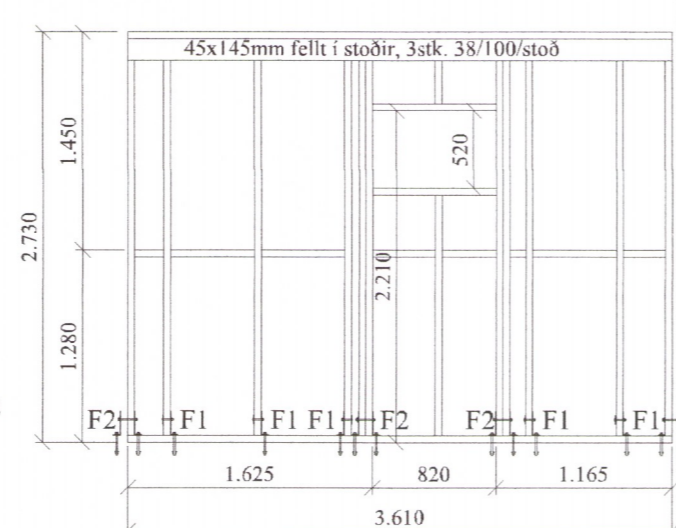

Grind nr. 3

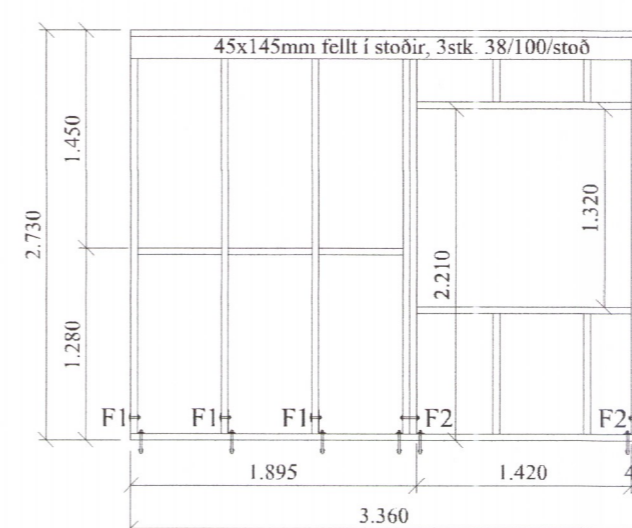

Grind nr. 4

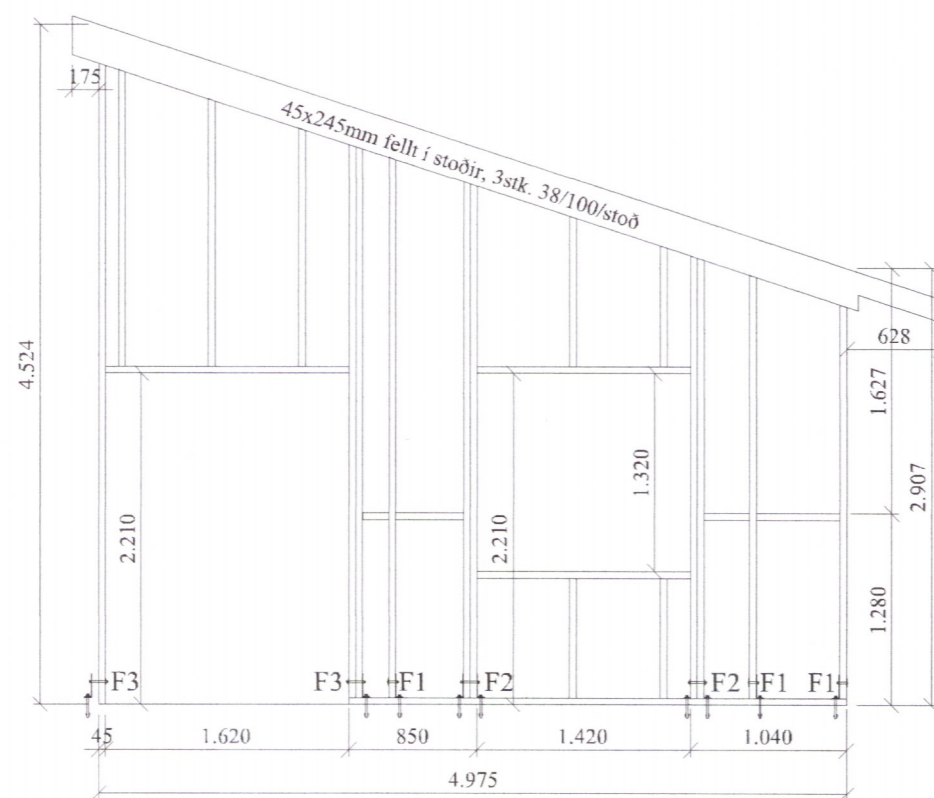

Grind nr. 5

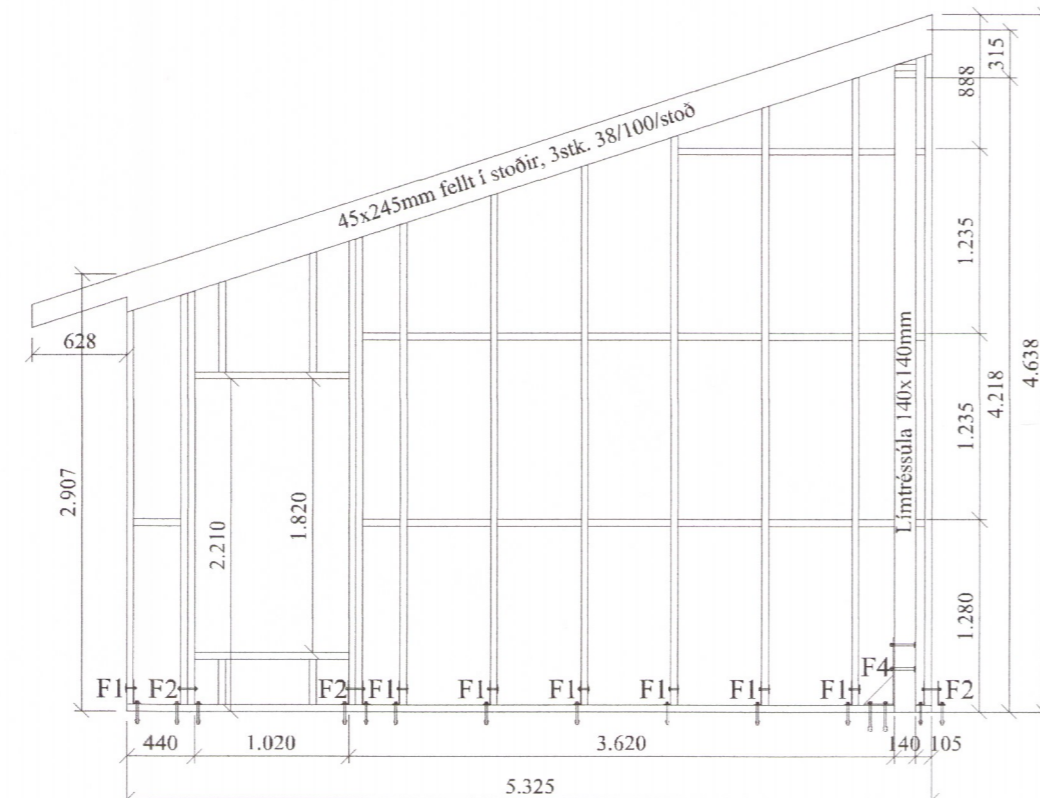

Grind nr. 6

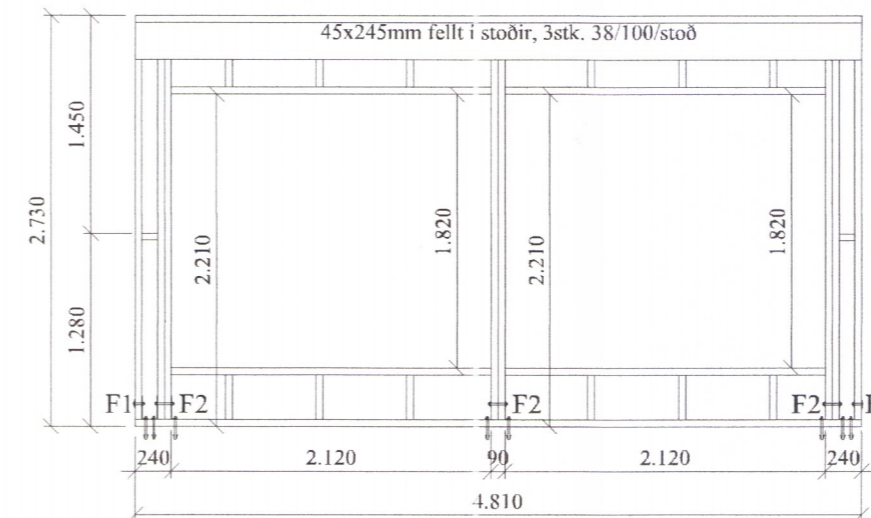

Grind nr. 7

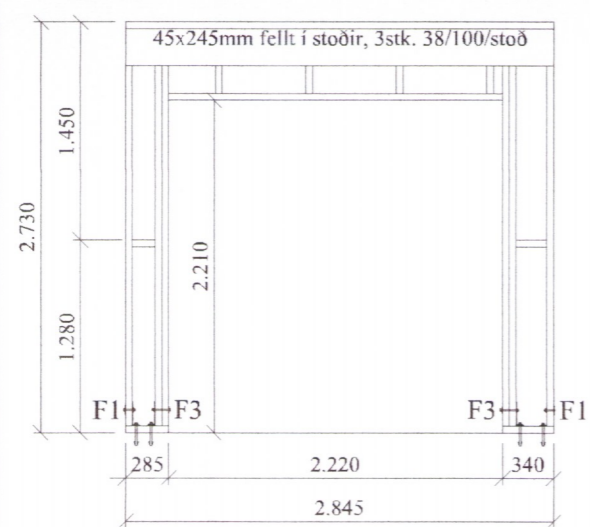

Grind nr. 8

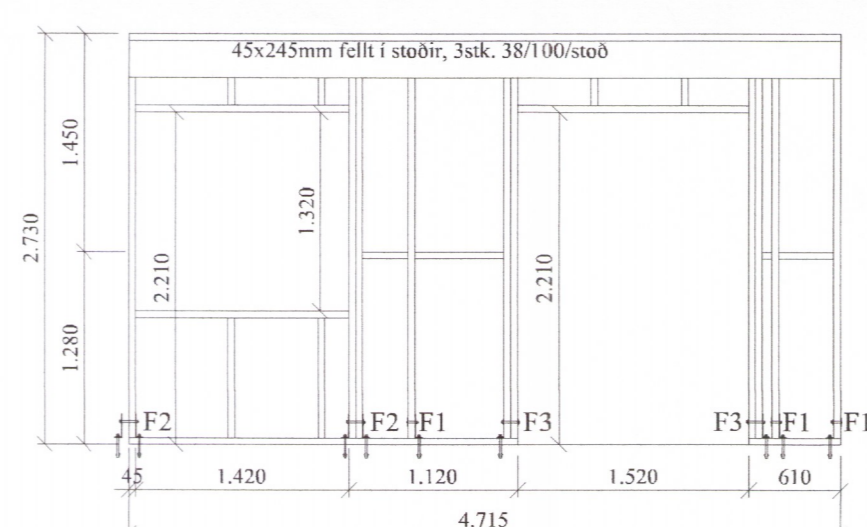

Grind nr. 9

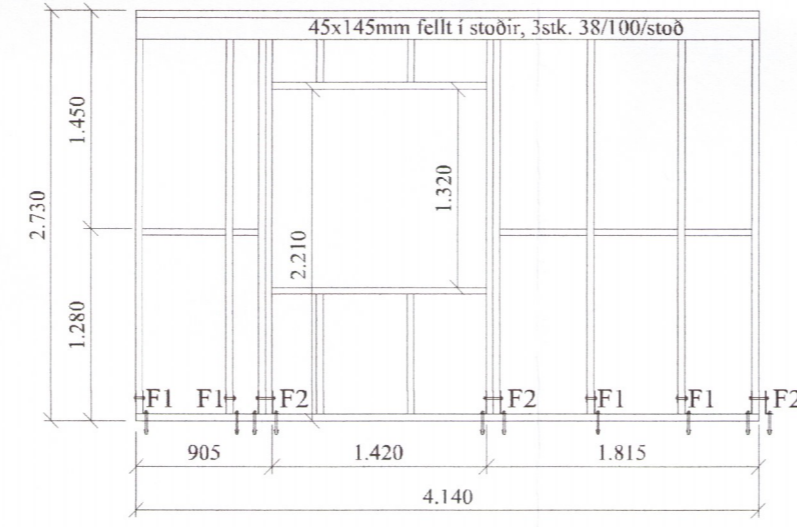

Grind nr. 10

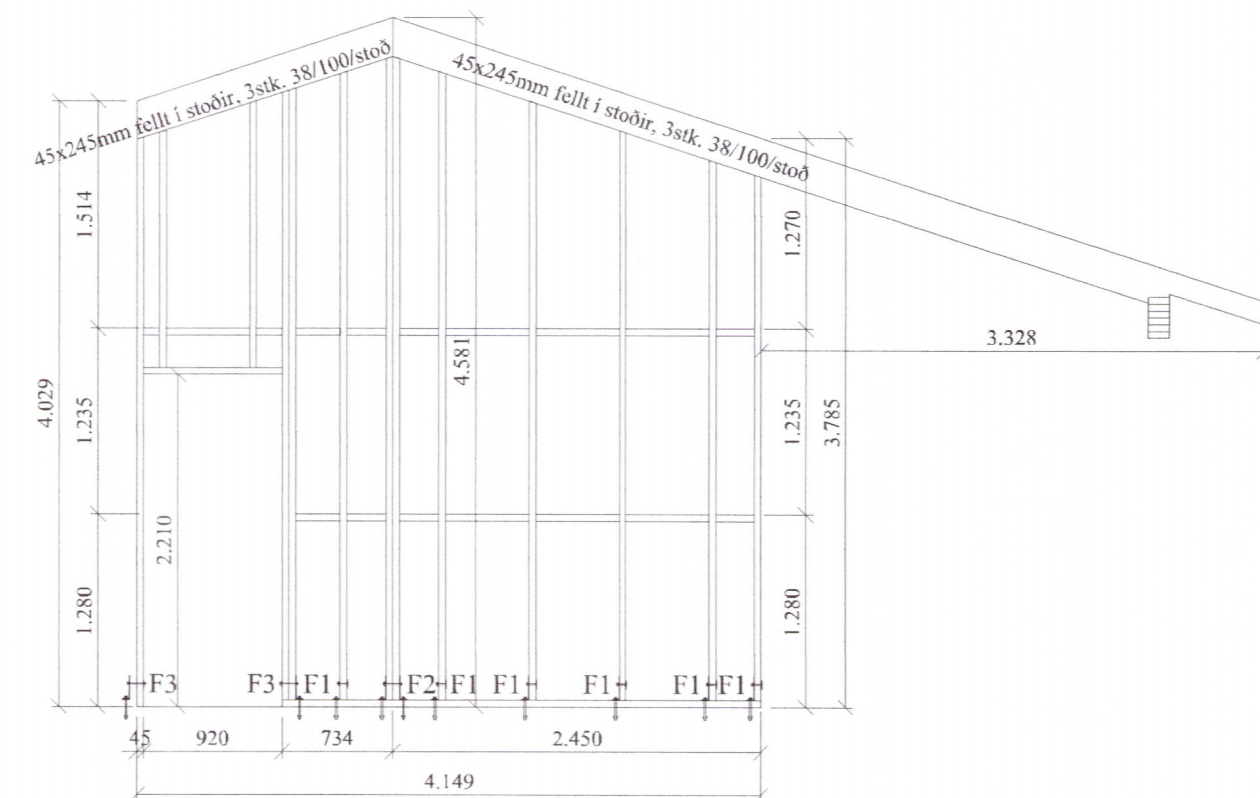

Grind nr. 11

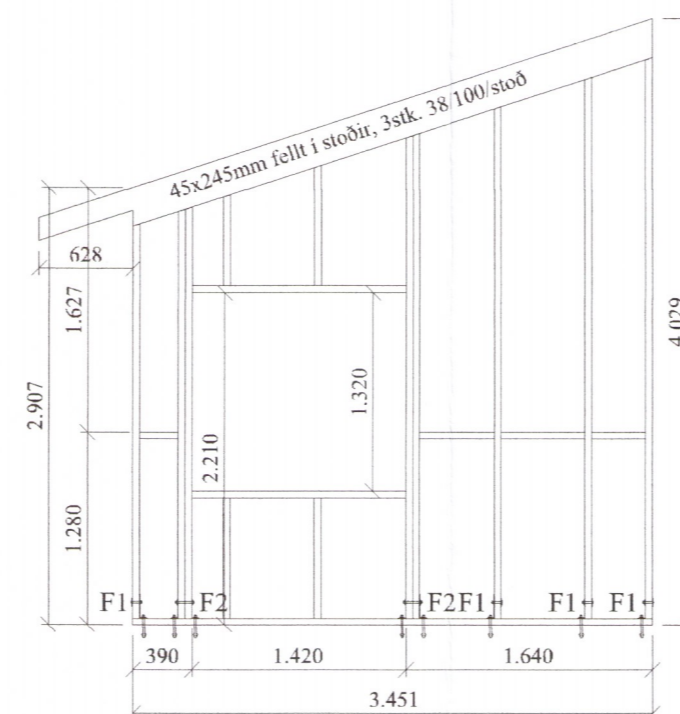

Grind nr. 12

**Almennt:**

Öll mál skulu staðfest skv. aðalteikningum.  
 Ef eitthvert misræmi er skulu aðalteikningar vera ráðandi, þó ber að láta hönnuði vita af misræmi.

**Skýringar - trévirki veggja**

Allur viður er C24 eða betri. Allan við utanhúss skal fúaverja. Allur saumur og festingar utanhúss skulu vera heitzinkhúðaðar eða ryðfríar. Allar stoðir og lausholt eru <sup>45</sup>/<sub>45</sub> nema annað sé tekið fram. Bil á milli miðjulina stoða skal ekki vera meira en 600 mm. Utan á grind komi 9 mm gufuopinn rakapólinn krossviður (t.d. grenikrossviður). Krossviður festist með <sup>3</sup>/<sub>65</sub> C150 í rakapólið lím. Þétting (Aerofil-púlsa eða Illmod þéttiborði) komi undir fótstykki, einnig skal setja vindpappa undir fótstykki, sem kemur þá á milli steypu og fótstykkis.

**Festingar á öllum samskeytum:**

Öll horn og einingasamskeyti skal vixlskrúfa saman með 6x80mm skrúfum c/c 400mm.

**Festing á fótstykki**

Múrboltar M12 C600 koma í gegnum fótstykki. Bordýpt = 105 mm og snertidýpt bolta við steypnan flöt => 80 mm.

F1 - F4  
 sjá sérmýndir.

2337-19

Br: Breyting	Dags:	Samb:
VERKHEITI: Bústjórabyggð 7 801 Grímsnesi	TEIKNINÚMÉR: 201	
VERKHLUTI: Burðarvirki Ásýnd grindur	ÚTGÁFA: A1	
Hönnuður: Leifur Örn Leifsson kt. 150982-4139 Sambýkkt: <i>Leifur Örn Leifsson</i>	BLADSTÆRÐ: A-2	
Yfirfarið af hönnunarstjóra: Bent Larsen Fróðason kt. 141177-3469 Sambýkkt: <i>Bent Larsen</i>	DAGS: 03.06.19	
<b>LARSEN</b> HÖNNUN OG RÁÐGJÖF	Bent Larsen Fróðason Byggingaráfræðingur B.Sc Sími 844-7659 tölvupóstur: bent@larsenhr.is	VERKNR: 18-20 MKV: 1:50