

ADALHÖNNUÐUR *Sigrún Þorsteinsdóttir*
 Jún. 2008 - Jún. 2016

Útg.	Dags.	Skýring	Braf.	Yfirf.
A	15.08.2017	Vinnuteikning	DSP	BJP
B	23.08.2017	Stöðvegur upp/æður	DSP	BJP
C	09.01.2018	Kantur hækkadur	DSP	BJP

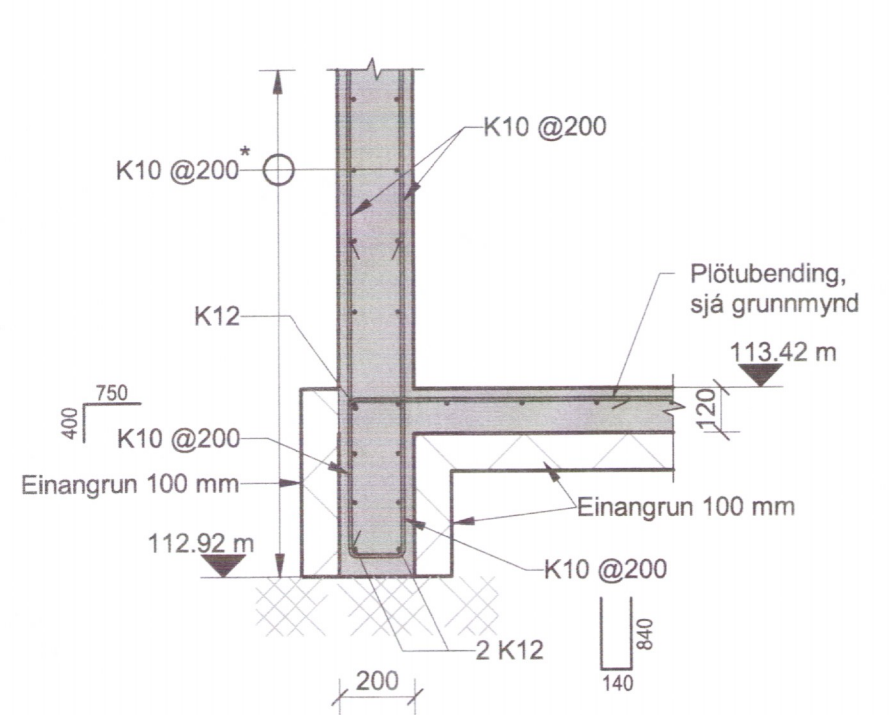

AA Snið AA
 01_1_21_01 1 : 20

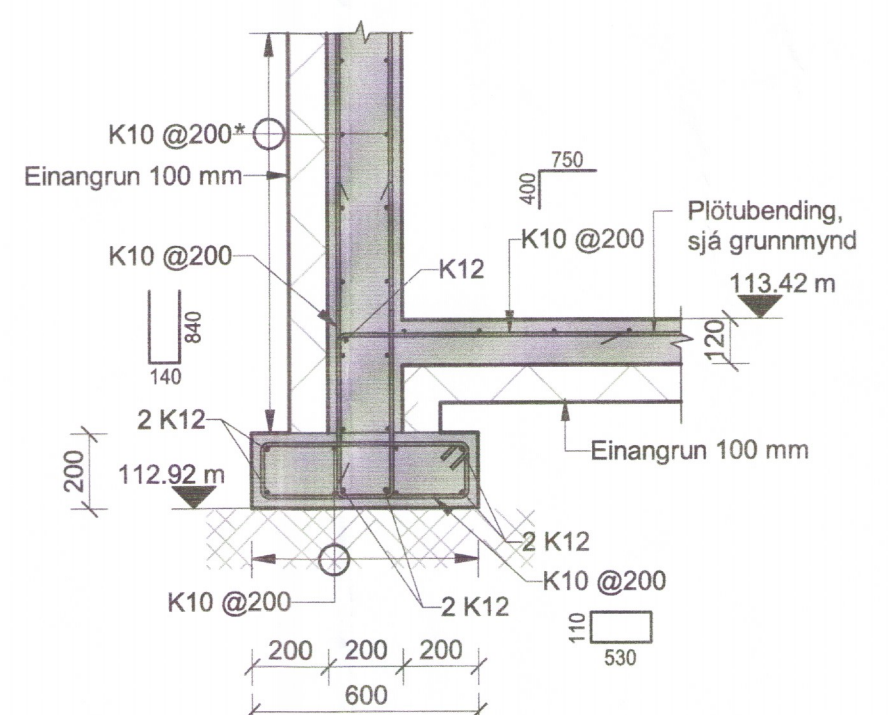

AB Snið AB
 01_1_21_01 1 : 20

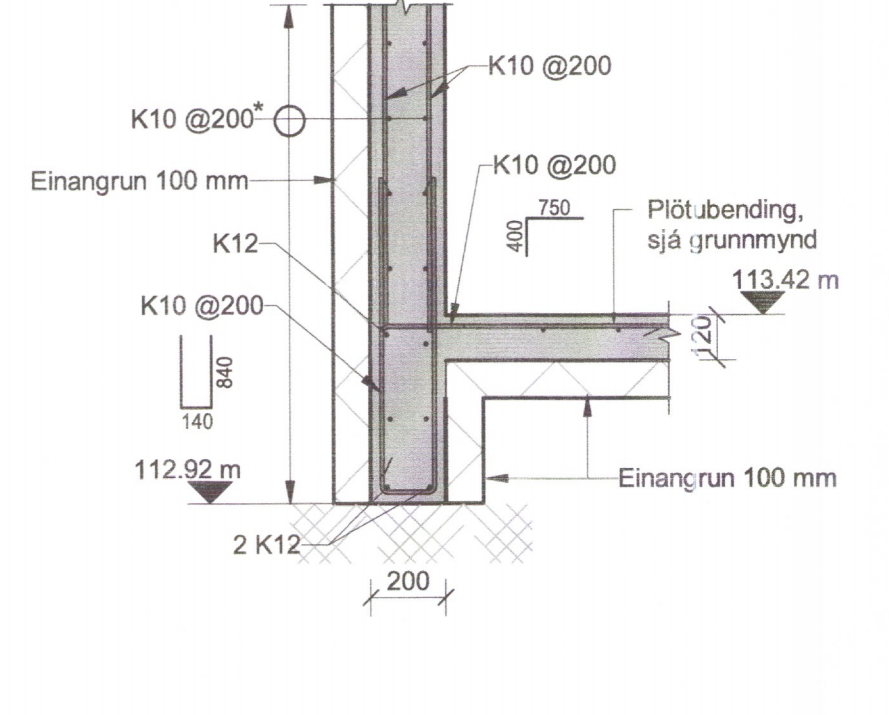

AC Snið AC
 01_1_21_01 1 : 20

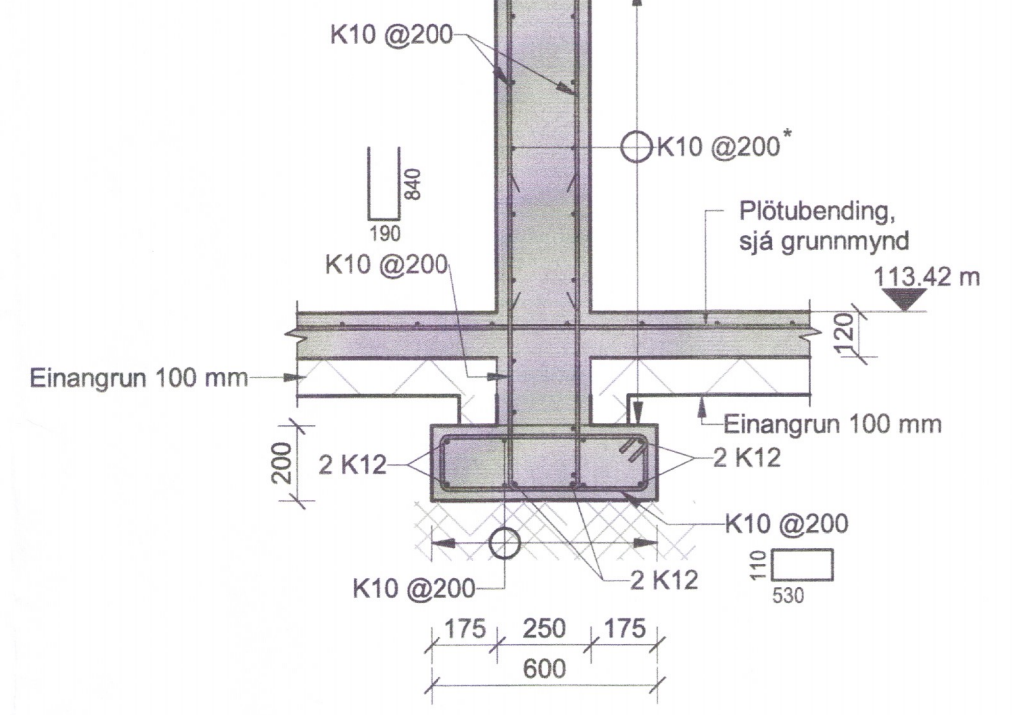

AD Snið AD
 01_1_21_01 1 : 20

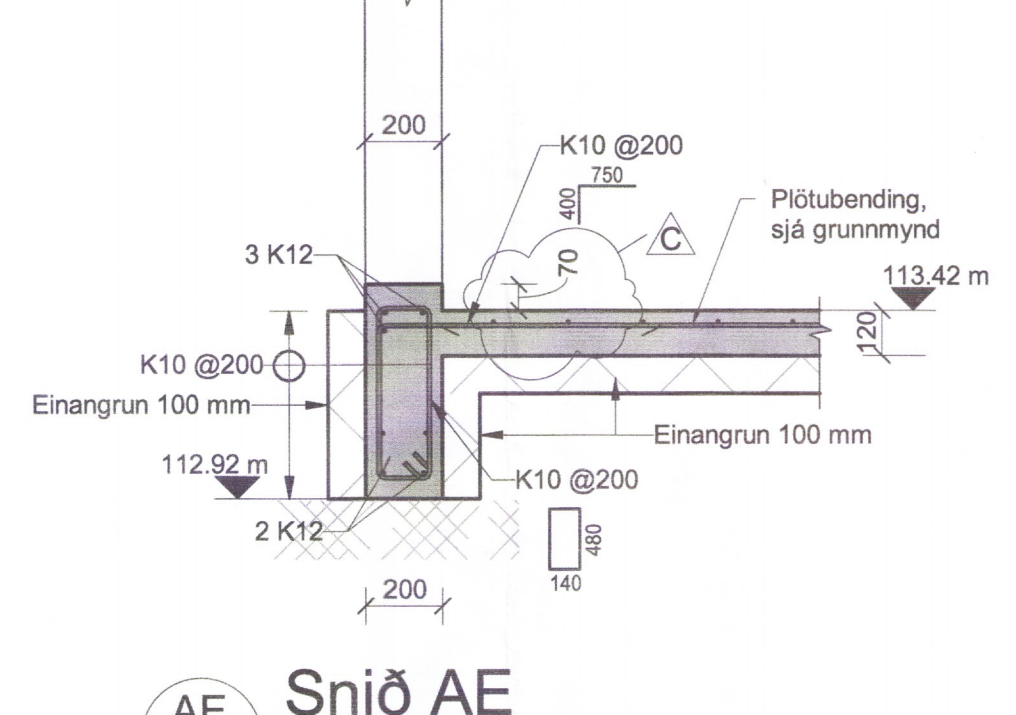

AE Snið AE
 01_1_21_01 1 : 20

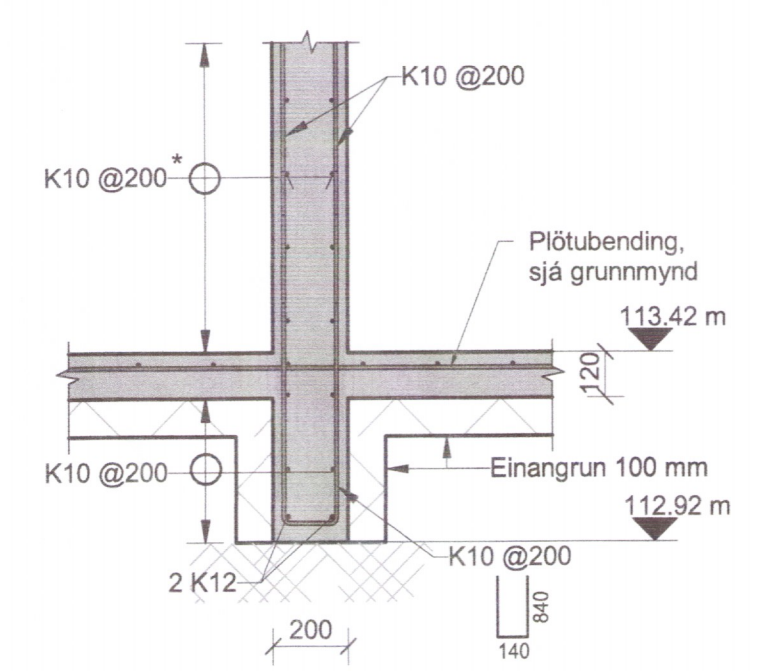

AF Snið AF
 01_1_21_01 1 : 20

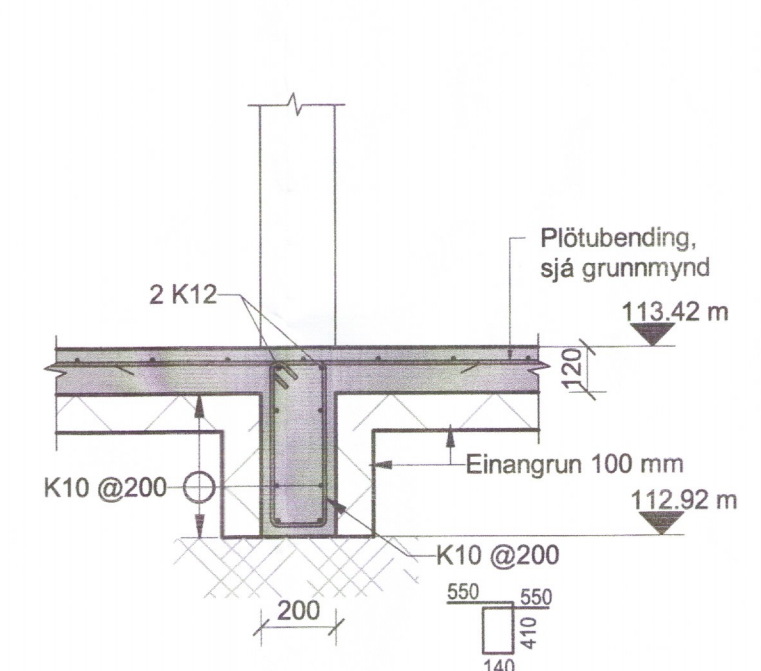

AG Snið AG
 01_1_21_01 1 : 20

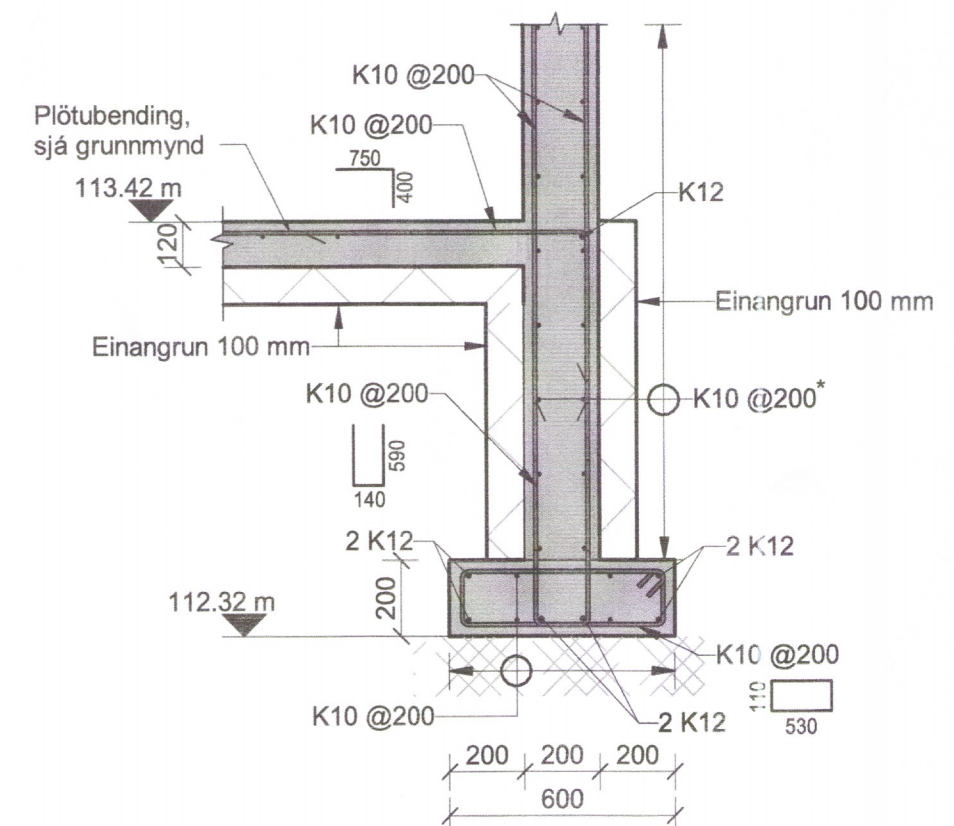

AH Snið AH
 01_1_21_01 1 : 20

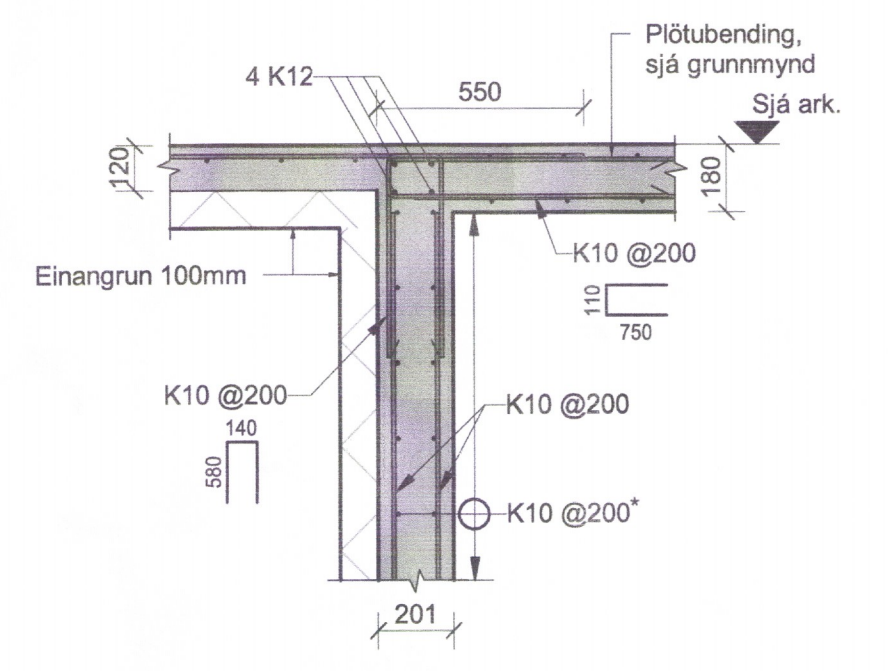

AJ Snið AJ
 00_1_21_01 1 : 20

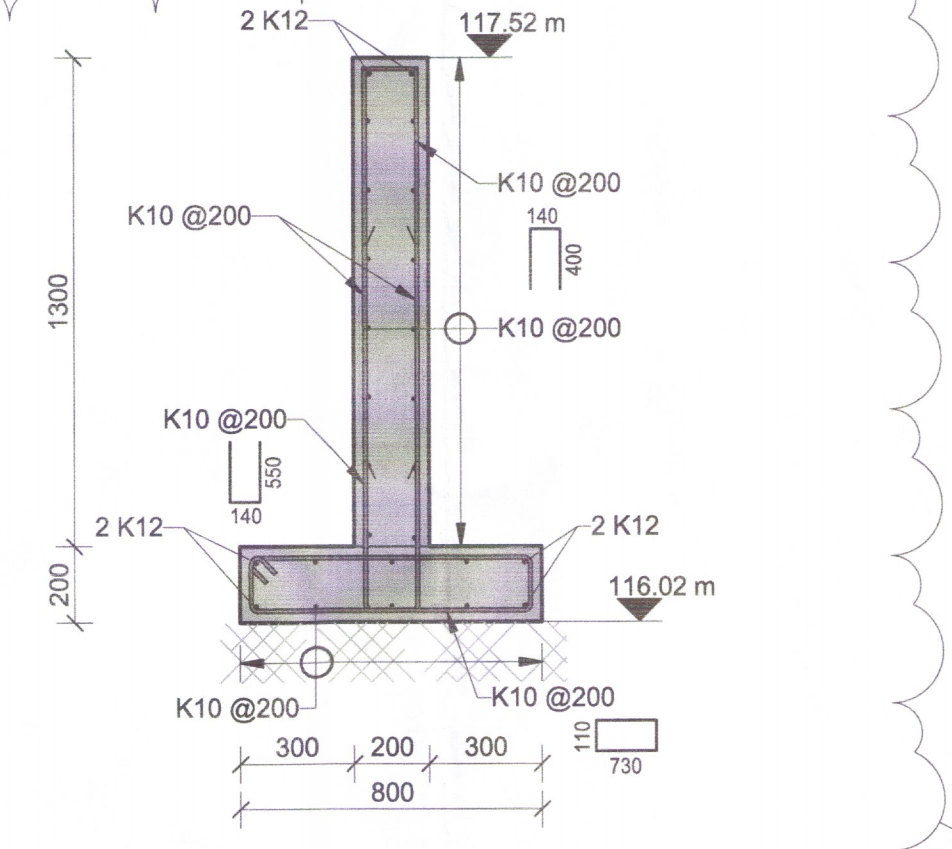

AK Snið AK
 00_1_21_01 1 : 20

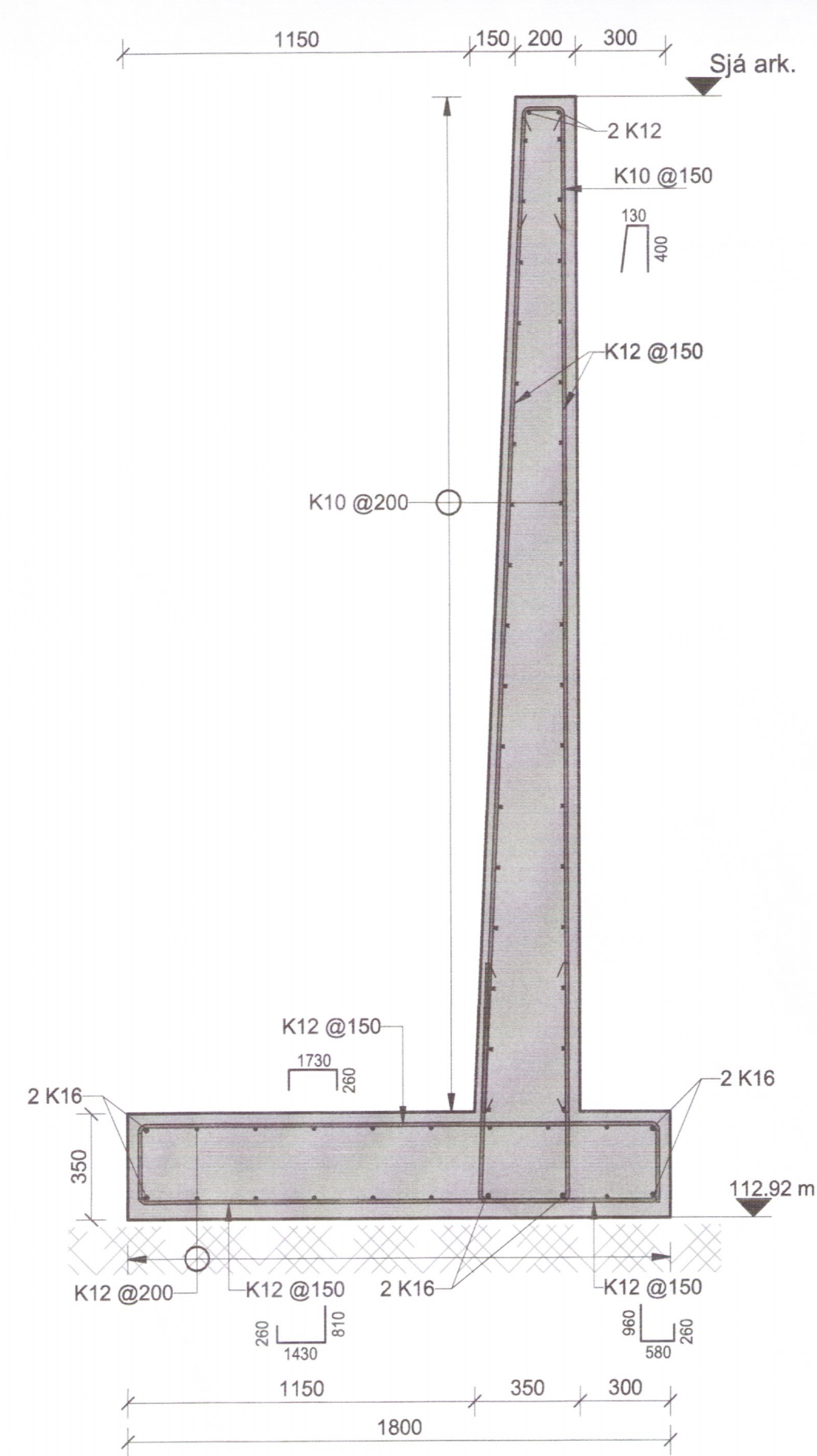

AI Snið AI
 01_1_21_01 1 : 20

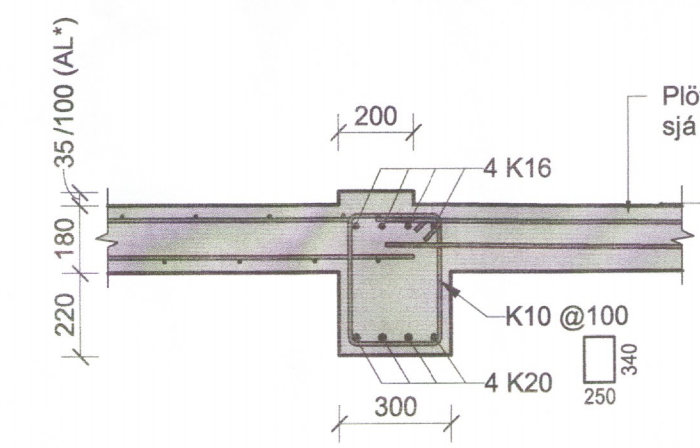

AL Snið AL
 01_1_21_01 1 : 20
 Snið AL* er sambærilegt nema steypur kantur er 100 mm upp úr

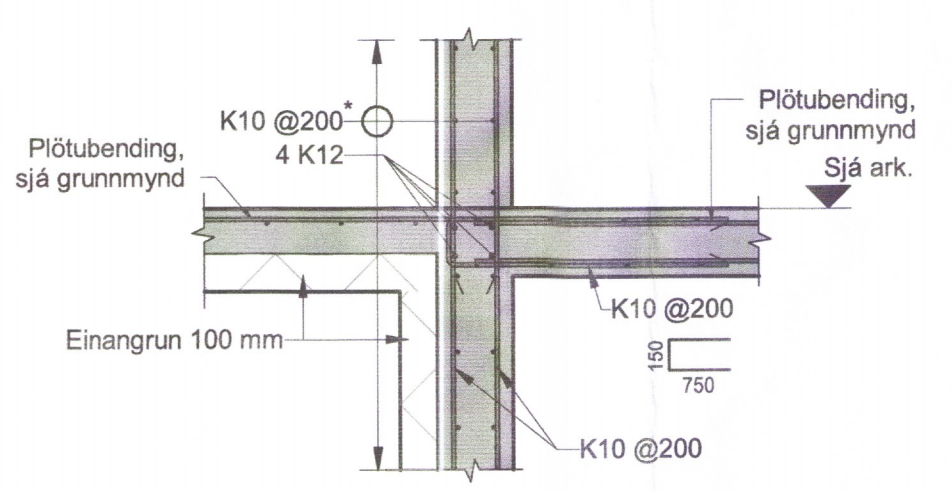

AP Snið AP
 01_1_21_01 1 : 20

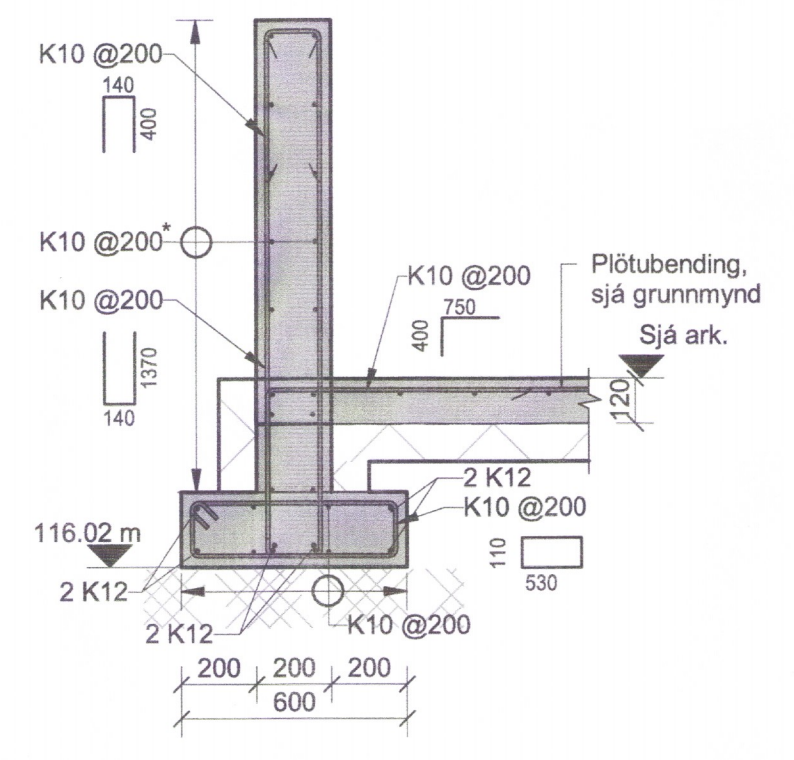

AQ Snið AQ
 01_1_21_01 1 : 20

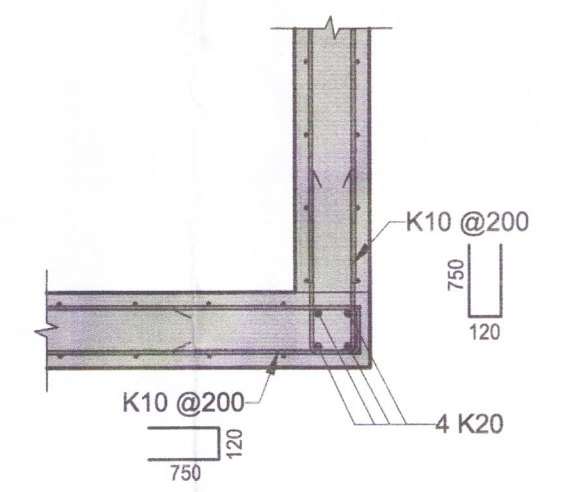

BC Deili BC
 00_1_21_01 1 : 20

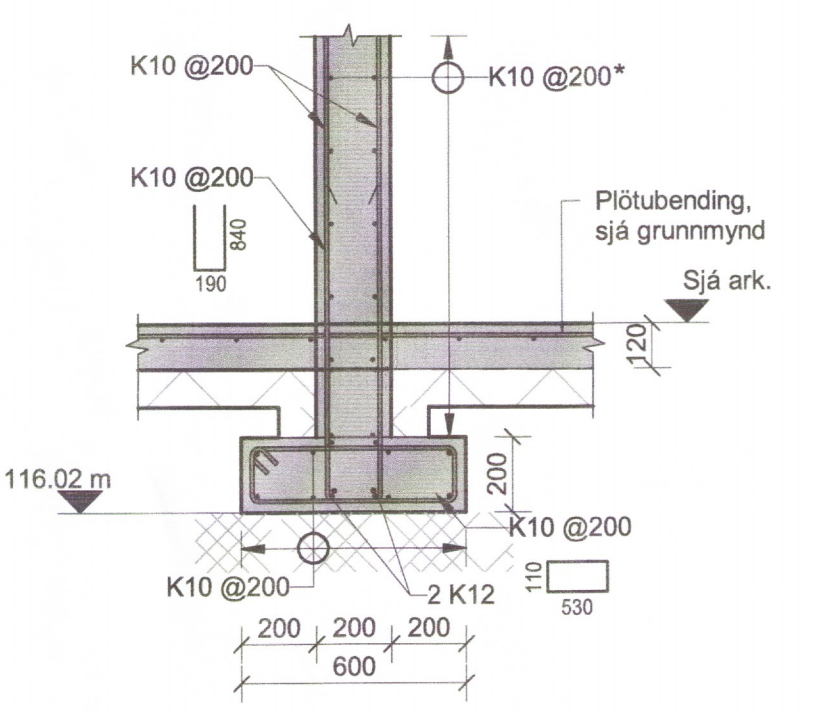

AR Snið AR
 00_1_21_01 1 : 20

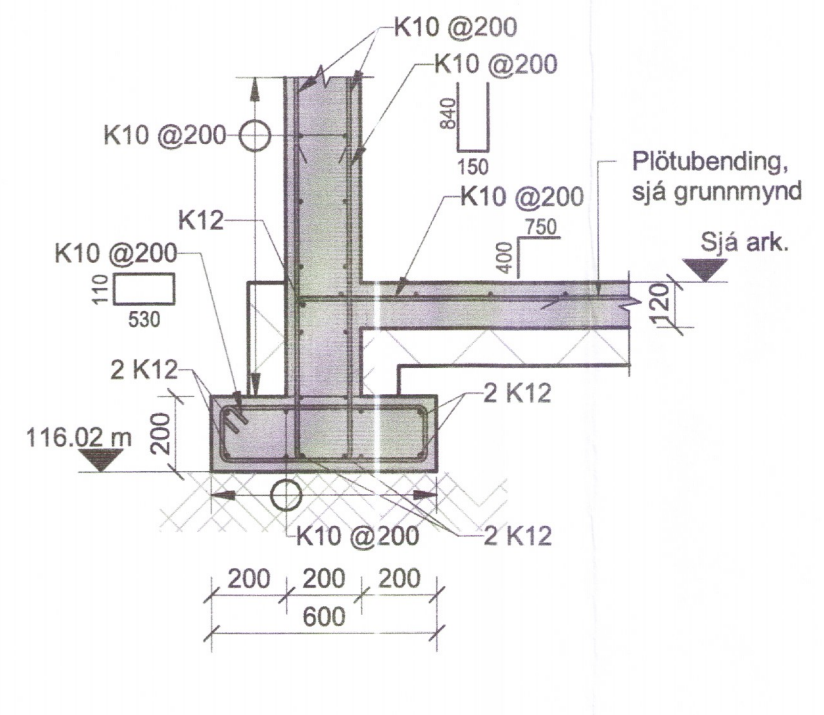

AS Snið AS
 00_1_21_01 1 : 20

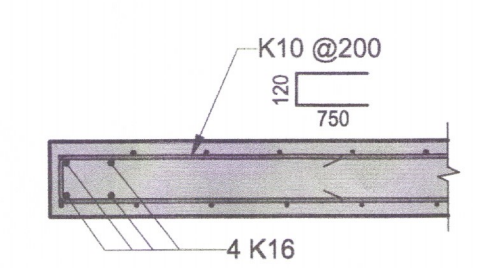

BI Deili BI
 00_1_21_01 1 : 20

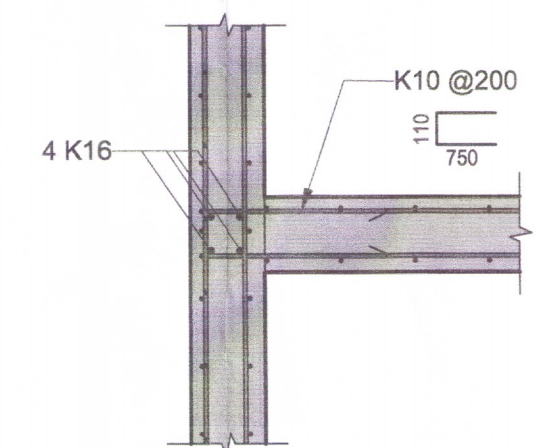

BJ Deili BJ
 00_1_21_01 1 : 20

Skýringar
 Öll mál eru í mm, hæðakótar í m nema annað sé tilgreint á teikningu
 Tilvísanir í teikningar:
 XX_1_04_01 Almennar skýringar
 XX_1_04_02 Kröfur til steinsteypu
 XX_1_04_03 Almennar kröfur til járnalagnar
 XX_1_04_04 Almenn Snið og deili fyrir járnalögn
 Sjá einnig teikningar arkitekta og lagnahönnuða

* K10@150 lárétt á sjónsteyptum flötum sem eru skilgreindir á teikningum arkitekta



Gata 4, Frístundahús
 845 Flúðum

Burðarvirki
 Járnbanding
 Snið 4679

TEKNI-NÚMÉR	BLADSTÆRD	HANNAÐ	DSP
4515-004	A1	TEKNAÐ: EDJ	
XX_1_23_01		YFRFARIR: BJP	
DAGS.	MELKVARDI	ÚTGÁFA	
15.08.2017		1 : 20	C

SAMPYKKT: *Bjarni P. Pálsson*
 KENNITALA: *291163-5139*