

20 1:10

ÁSETA FYRIR MÆNISBITA Í ÚTVEGGJUM

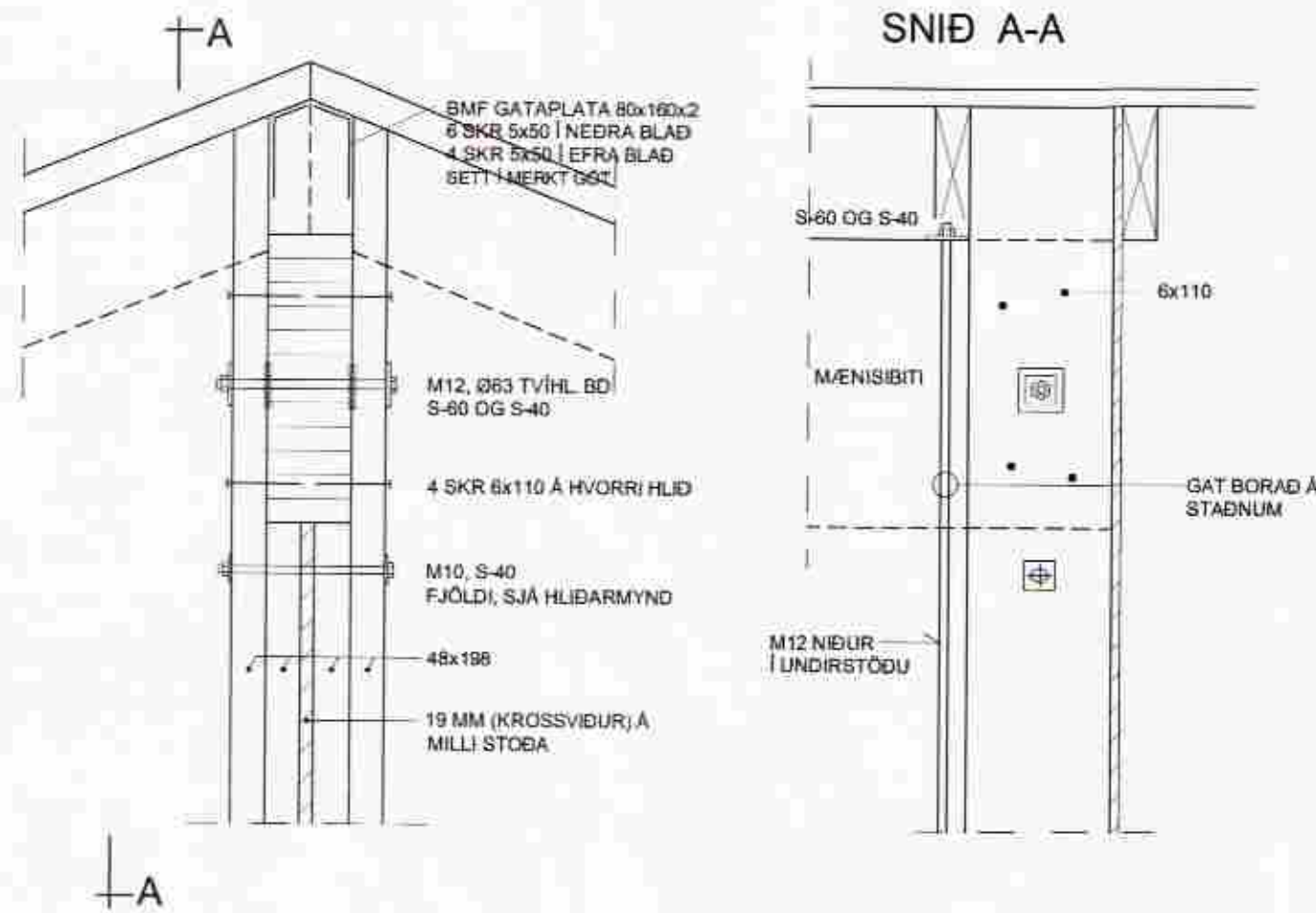

22 1:10

SAMSETNING Á VEGGHÖRNUM VÍÐ GAFLVEGGI, ÖÐRUM EN VÍÐ BÍLSKÚRSDYRAOP  
GAFLAR GANGA ÚT FYRIR HLÍÐAR

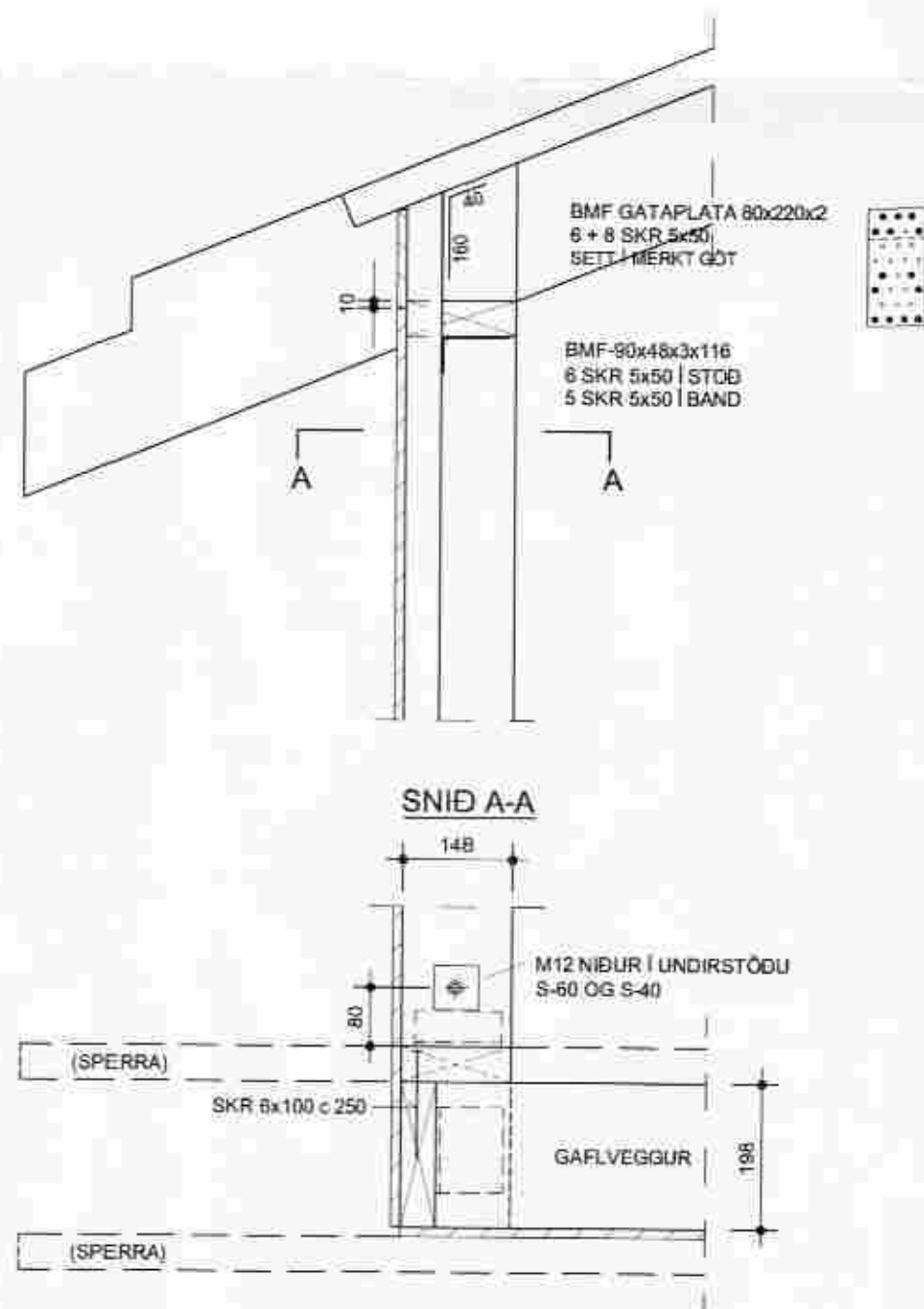

21 1:10

SAMSETNING Á VEGGHÖRNI VÍÐ BÍLSKÚRSDYRAOP / GAFL  
LAGHLÍÐ GENGUR HÉR ÚT FYRIR GAFL

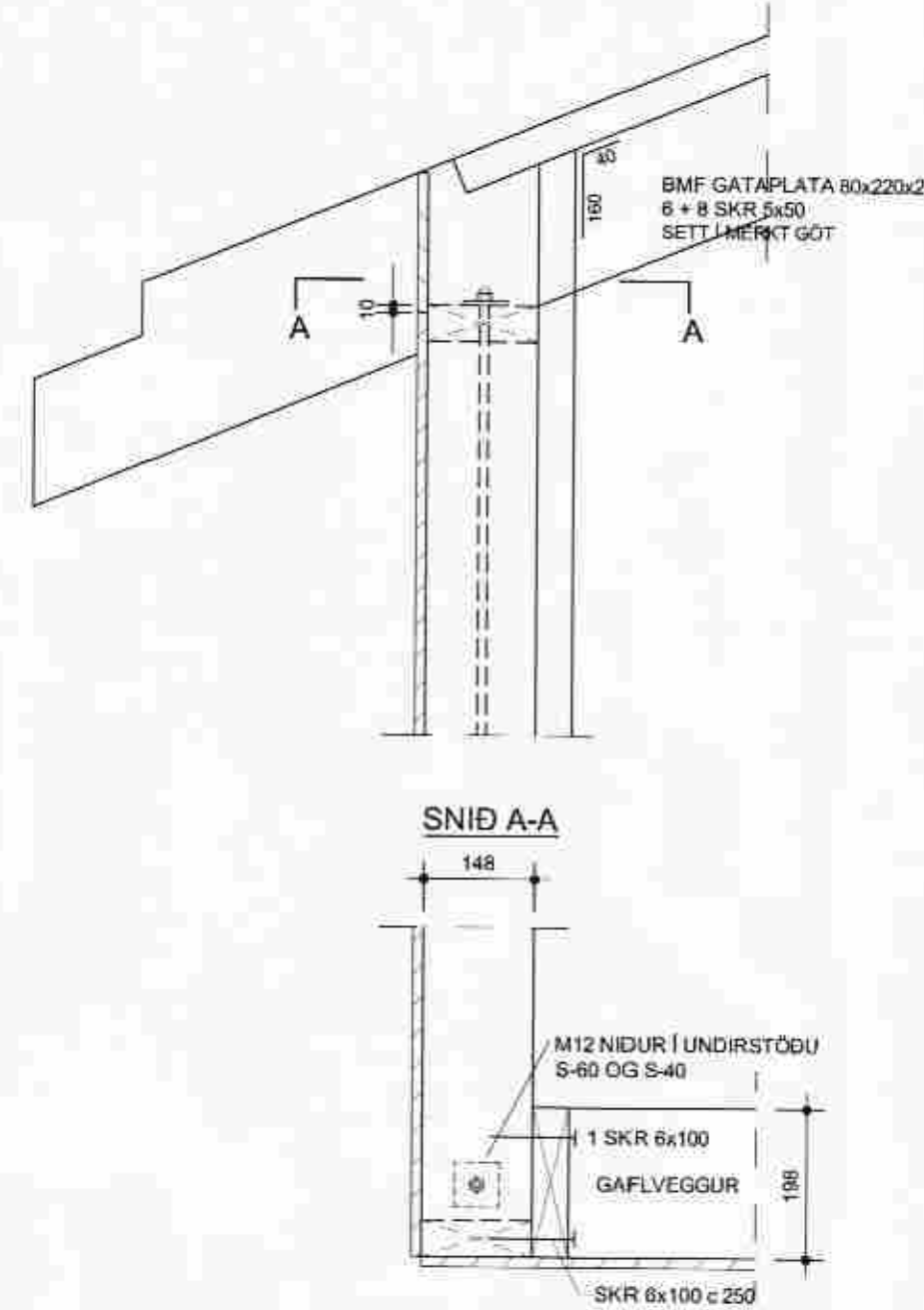

23 1:10

BOLTAFESTING VÍÐ GÖLF (10 STK)



24 1:10

BOLTAFESTING VÍÐ GÖLF

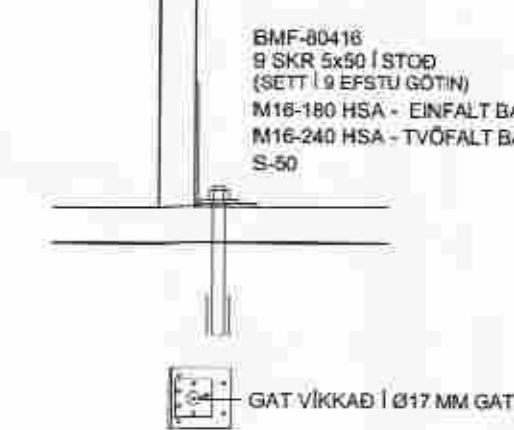

FESTING STÖÐA VÍÐ GÖLF- OG YFIRBAND

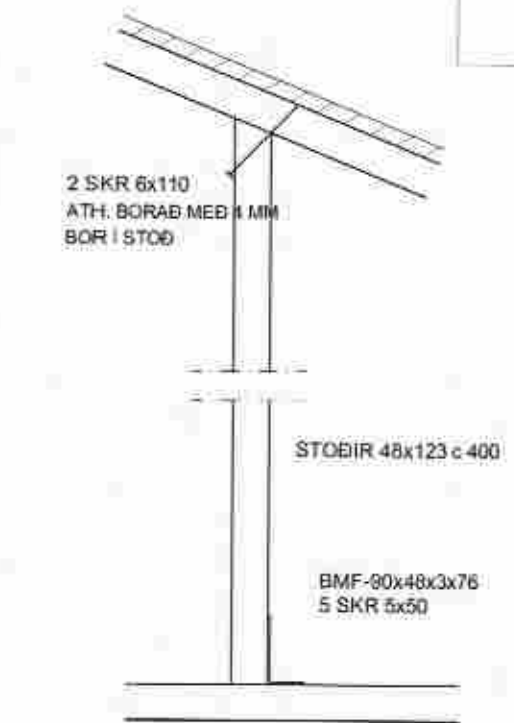

25 1:10

TENING VÍÐ ÞAK

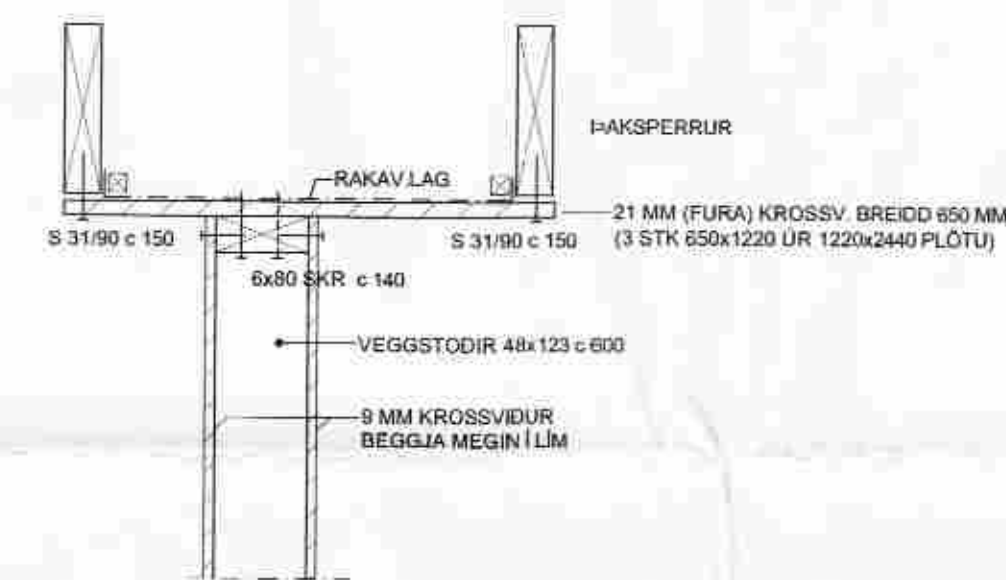

26 1:10

TENING ÚTVEGG

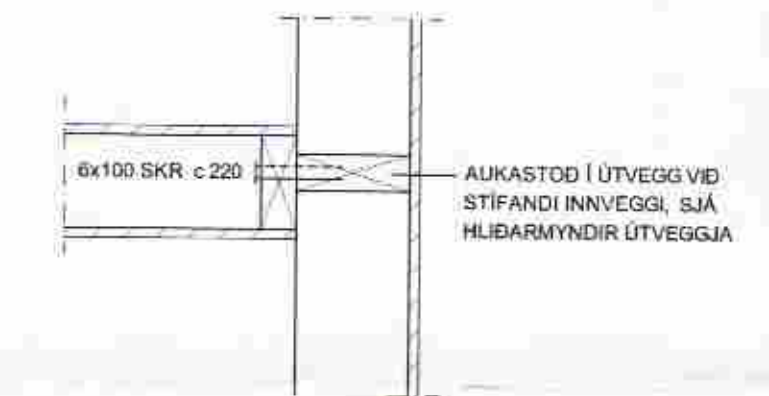

27 1:10

TENING VÍÐ STÁLSTÖÐIR

