

B SNIÐ B-B 1:20

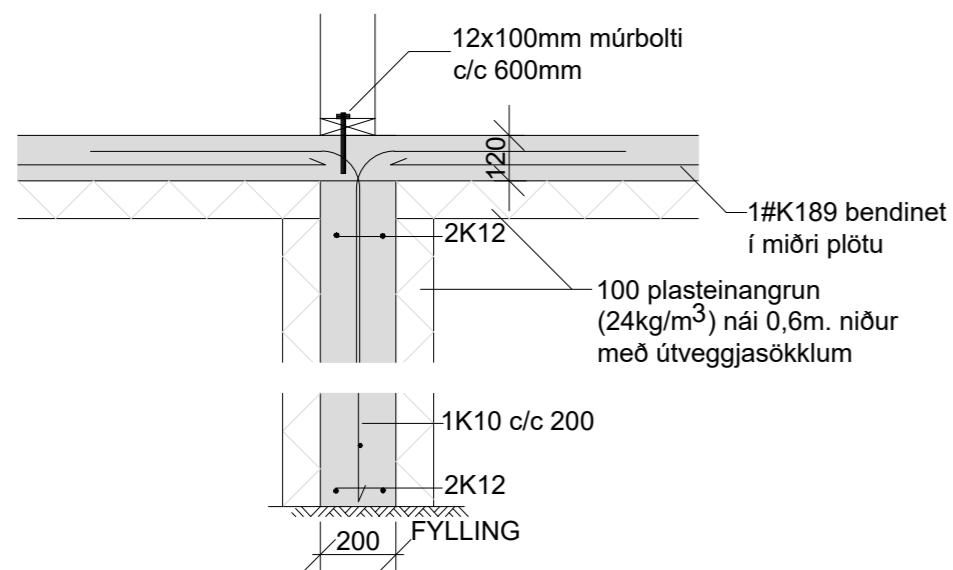

A SNIÐ A-A 1:20

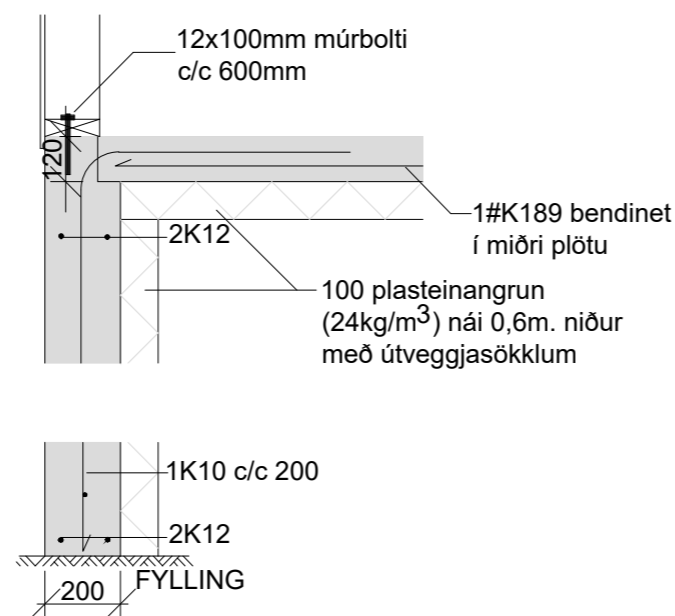

C SNIÐ C-C 1:20

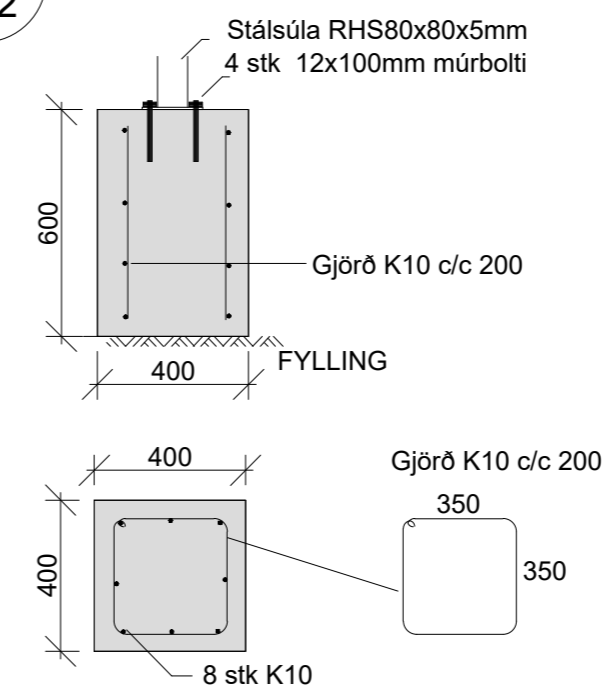

Samþykki arkitekts:

A2

Giljatunga 29 í landi Ásgarðs
Grunnmynd og sniðsökkla og botnplata

TEIKNINÚMÉR	MÆLIKVARDI	ÚTGÁFA
B-02	1:50 1:20	1
Hafsteinn Kr. Halldórsson Byggingatæknifræðingur FTFÍ kt: 120166-3449 hafsteinn.kh@gmail.com	NAFN	DAGSETNING
	hak	10.08.2022
	hak	10.08.2022
	YFIRFARIÐ	

SAMP. NR. *Hafsteinn Kr. Halldórsson*

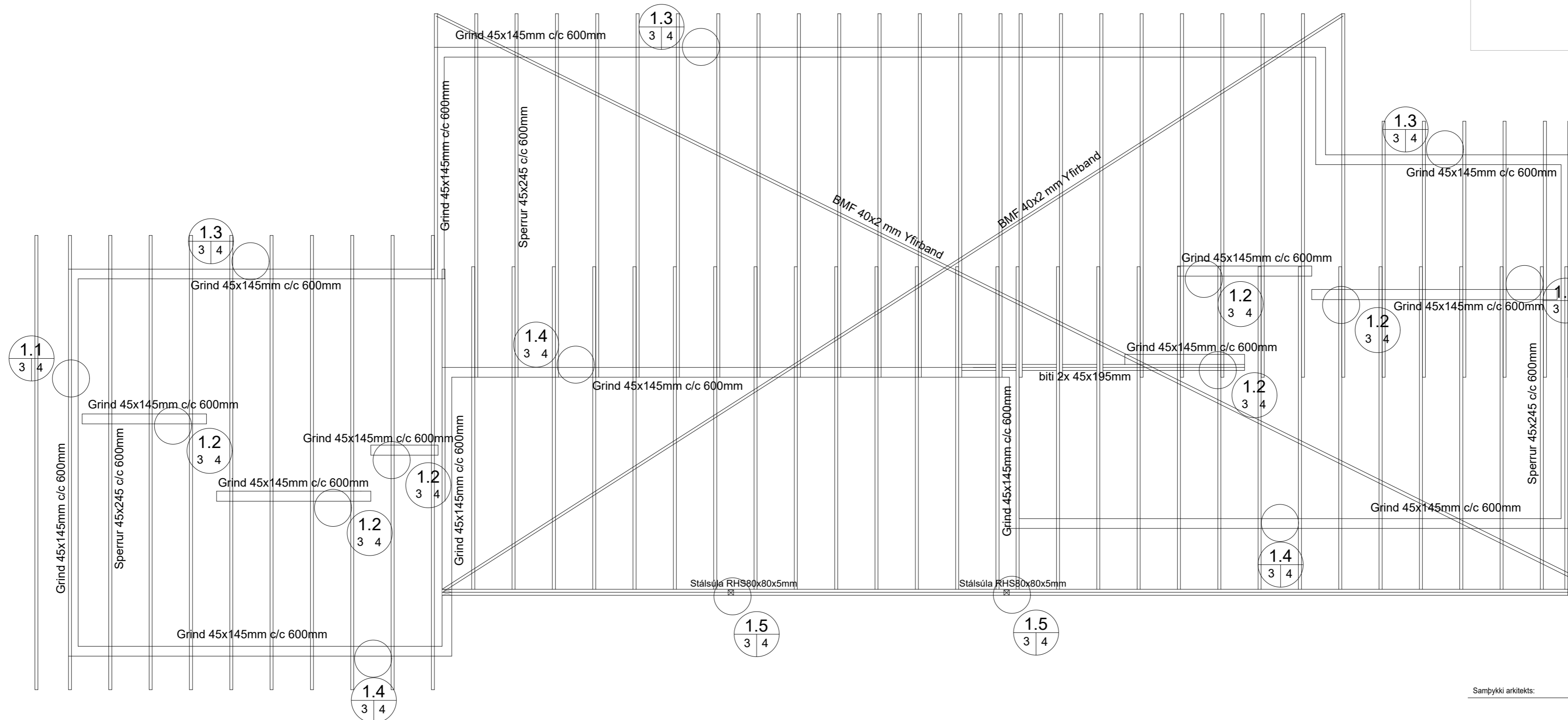

Grunnmynd og sperruplan 1:50

Samþykki arkitekts:

A2

Giljatunga 29 í landi Ásgarðs
Grunnmynd og sperruplan

TEIKNINÚMUR	MÆLIKVARDI	ÚTGÁFA
B-03	1:50	1
Hafsteinn Kr. Halldórsson Byggingatæknifræðingur FTFÍ kt: 120166-3449 hafsteinn.kh@gmail.com	NAFN	DAGSETNING
	hannab	10.08.2022
	TEIKNAB	hak
	YFIRFARIÐ	
SAMP. NR.		

1.1 Sérmynd 1.1 1:10

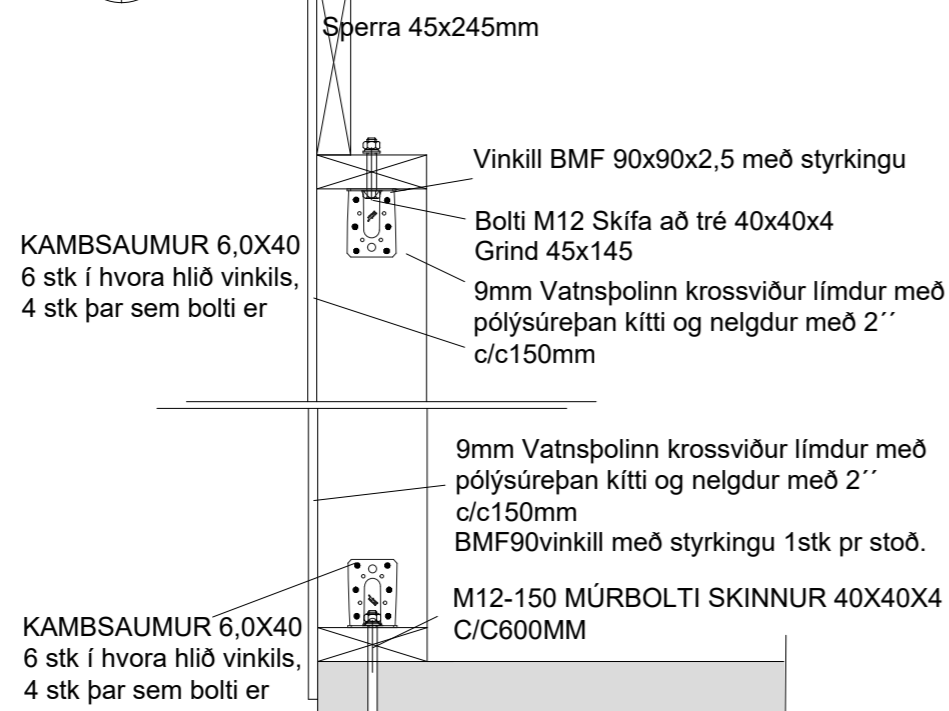

1.2 Sérmynd 1.2 1:10

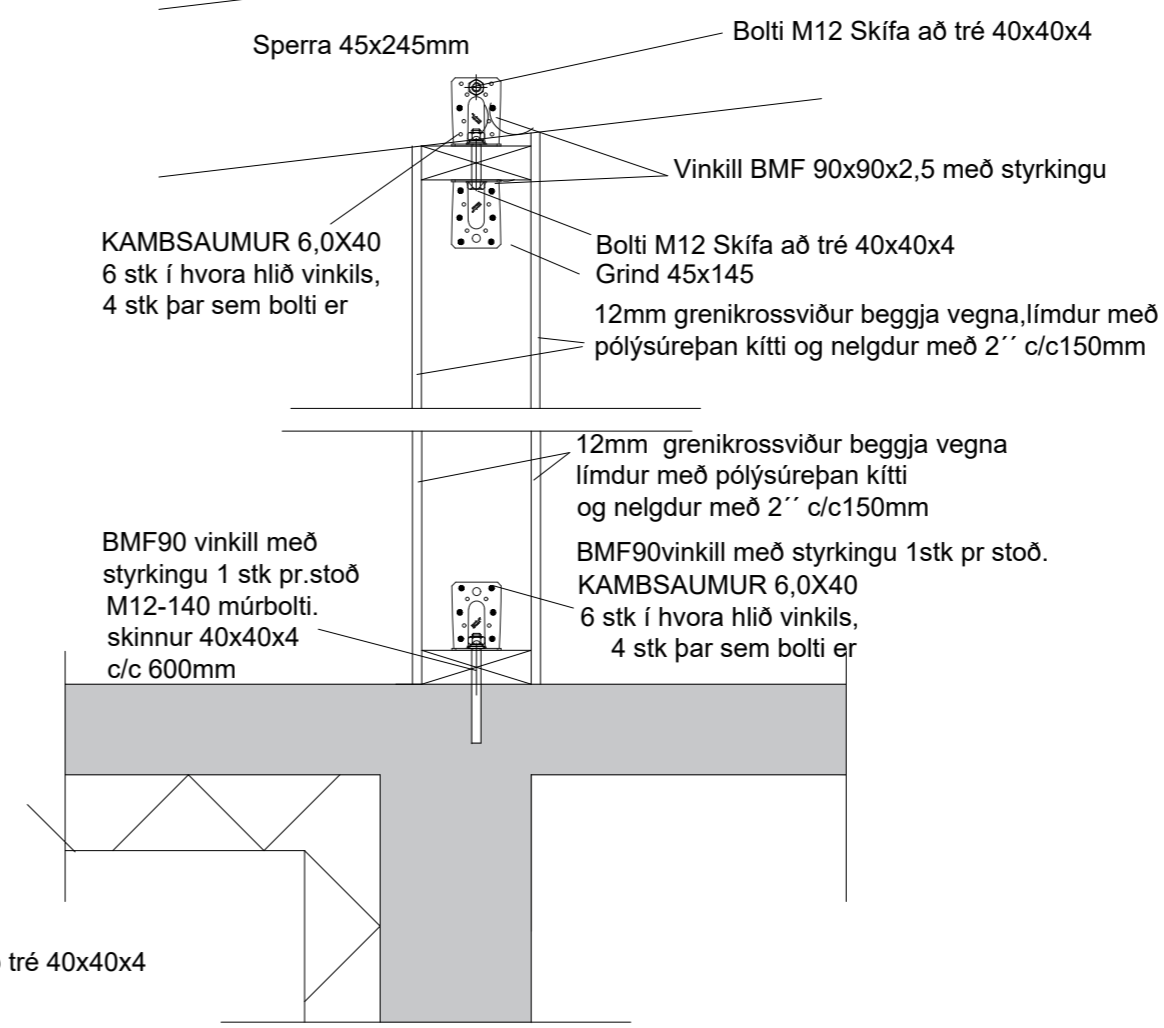

1.3 Sérmynd 1.3 1:10

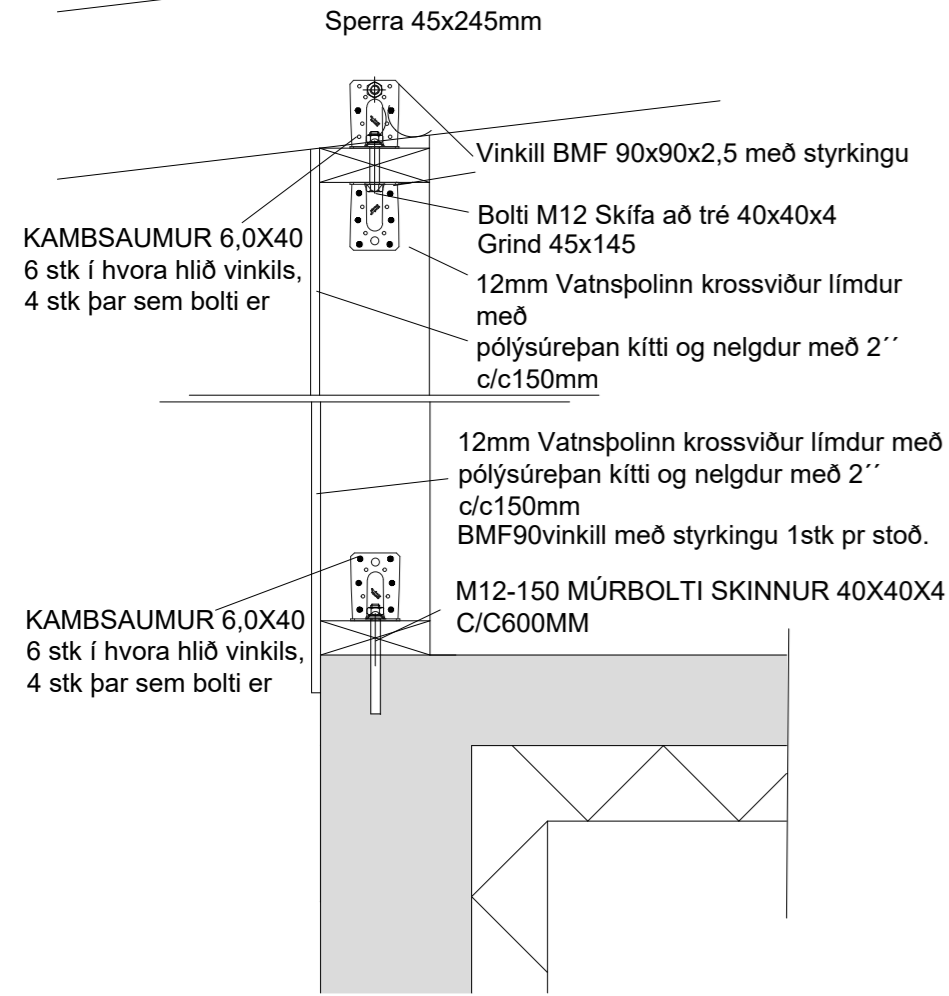

1.4 Sérmynd 1.4 1:10

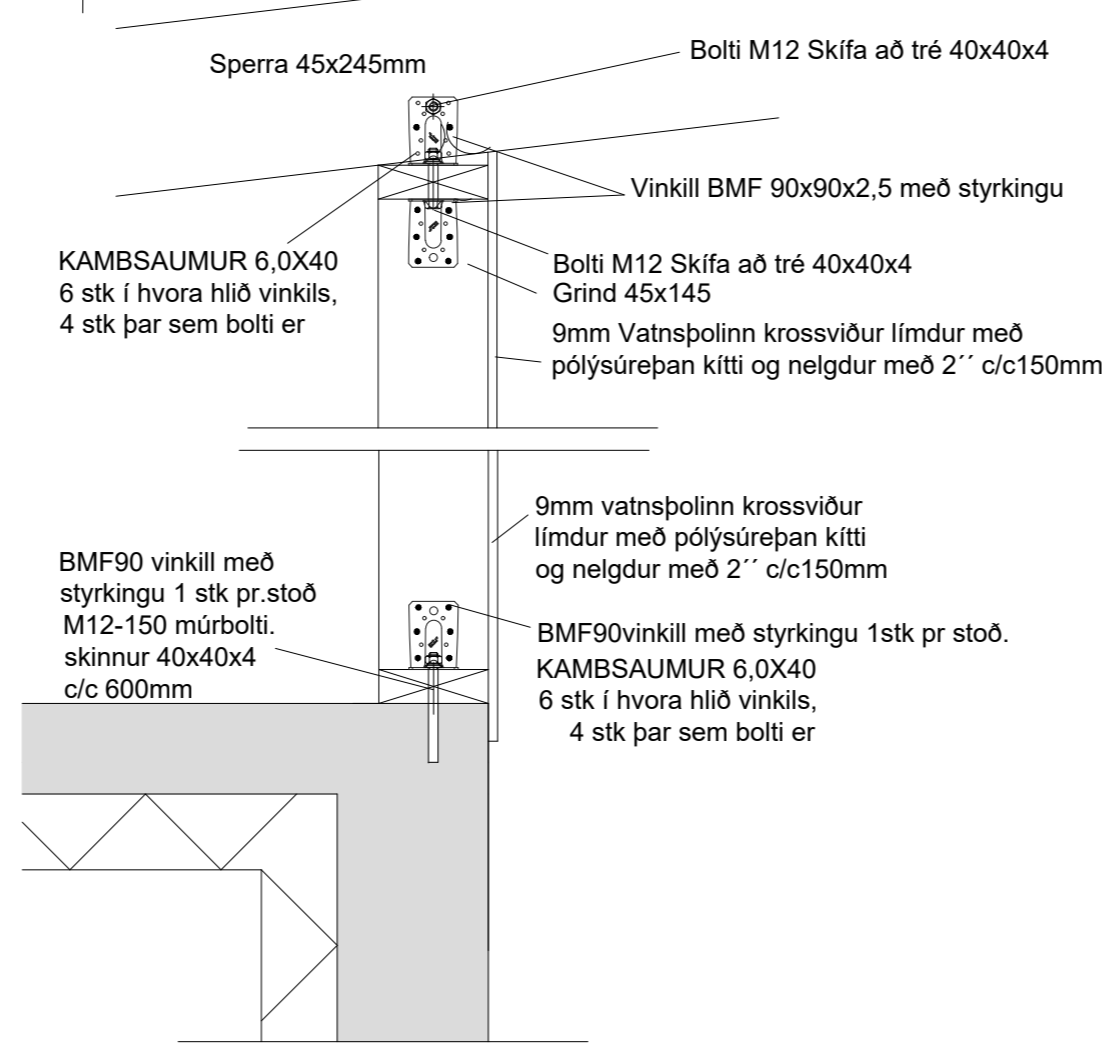

1.5 Sérmynd 1.5 1:10

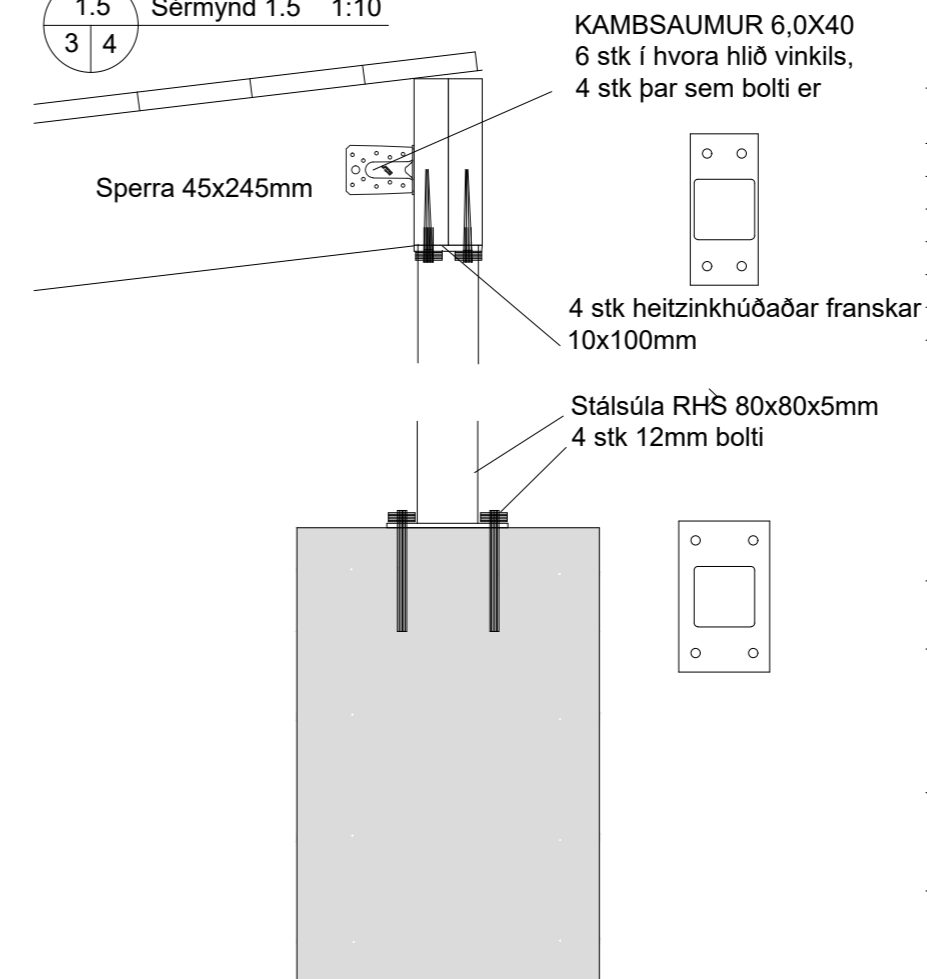

Burðarþol: hliðarmynd útveggjagrindar 1:50

1.1 3 4

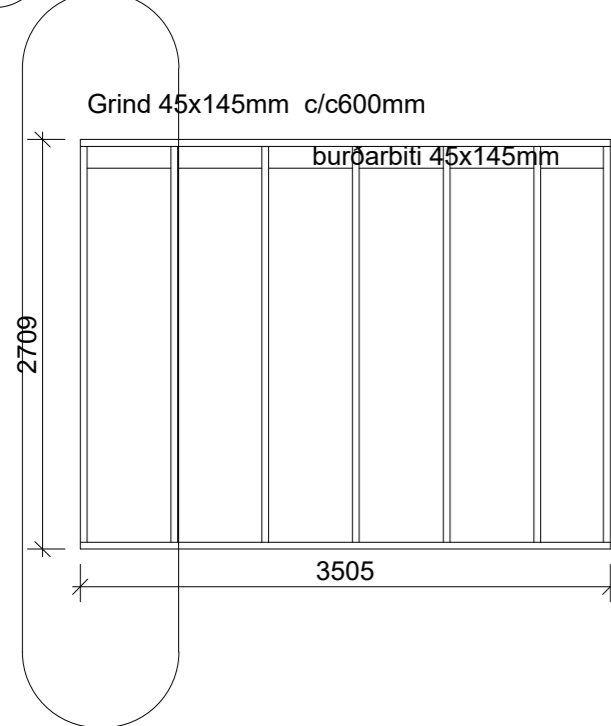

1.3 3 4

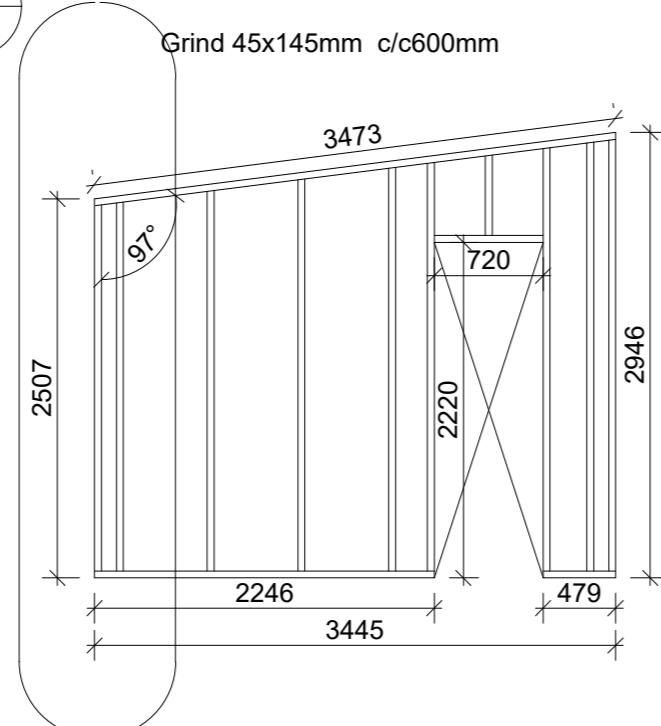

1.4 3 4

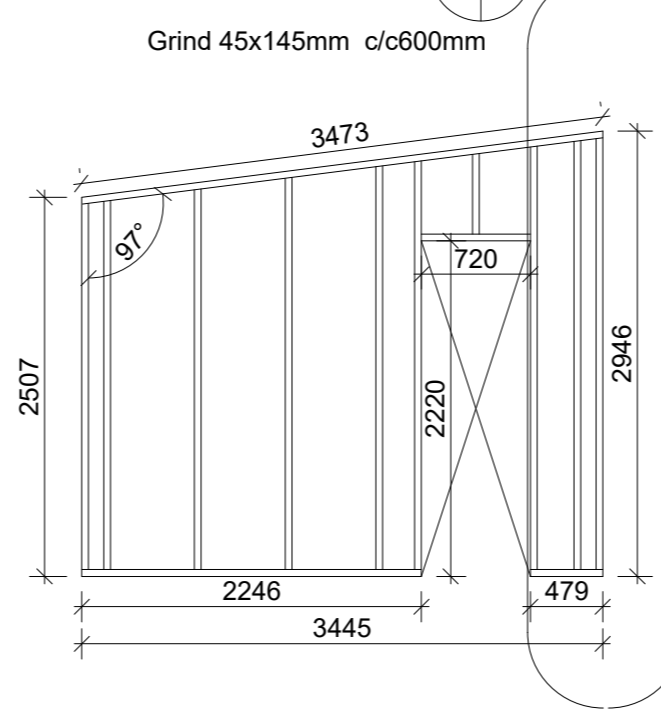

Samþykki arkitekts:

A2

Giljatunga 29 í landi Ásgarðs
Burðarþol, sérmyndir og hliðarmynd útveggjagrindar

TEIKNINUMER	MÆLIKVARDI	ÚTGÁFA
B-04	1:10 1:50	1
Hafsteinn Kr. Halldórsson Byggingatæknifræðingur FTFÍ kt: 120166-3449 hafsteinn.kh@gmail.com	NAFN	DAGSETNING
	HANNAÐ hak	10.08.2022
	TEIKNAD hak	10.08.2022
	YFIRFARID	

SAMP. NR. *Hafsteinn Kr. Halldórsson*

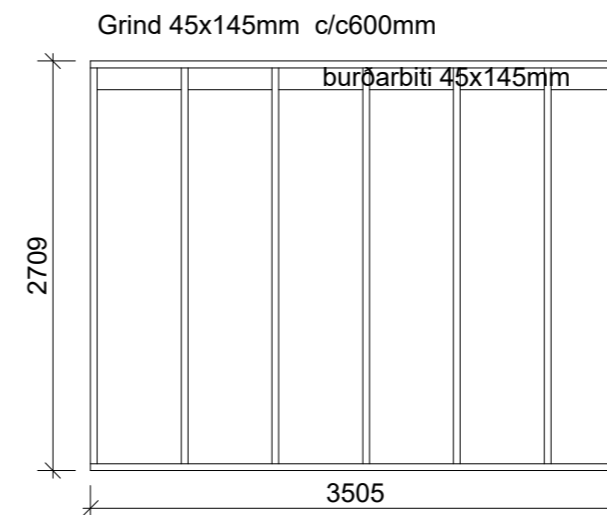
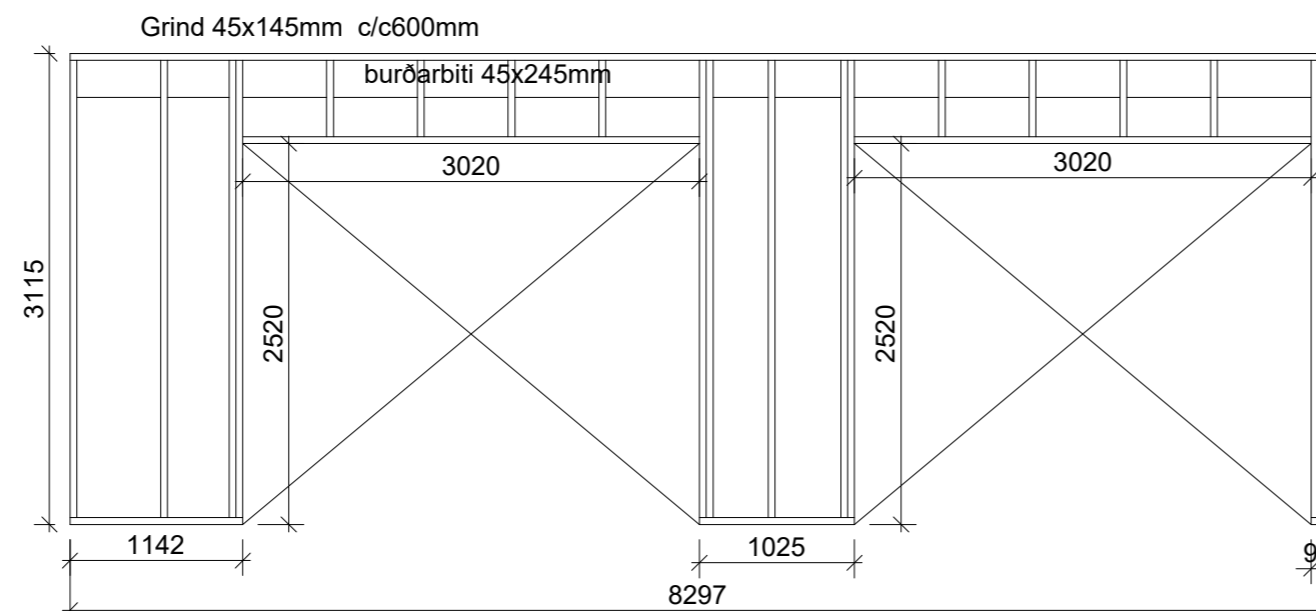
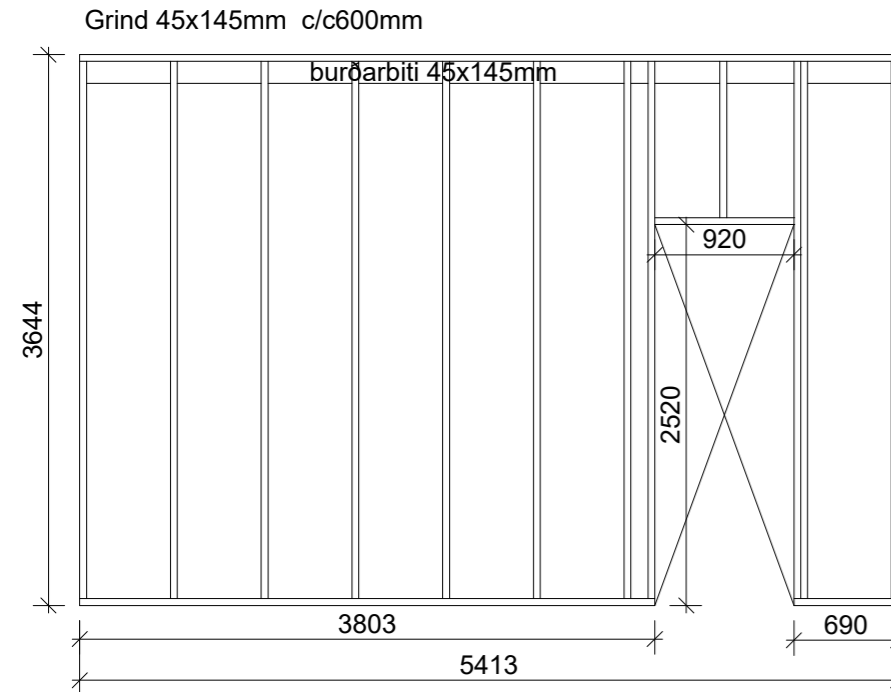
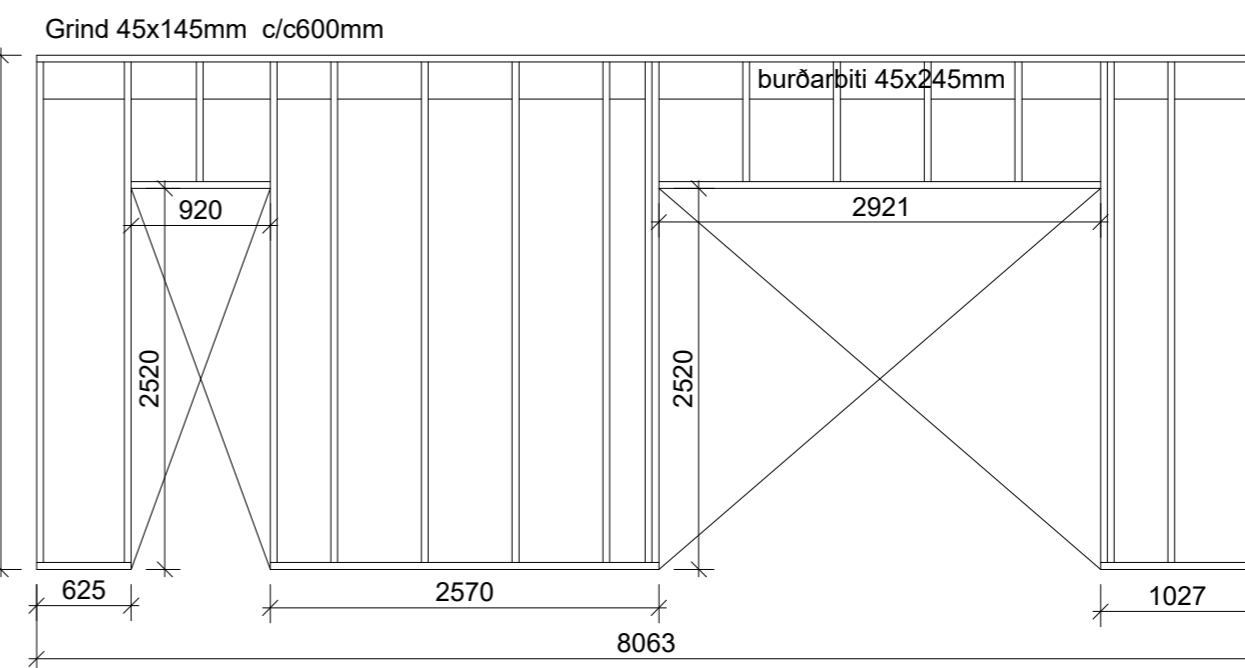
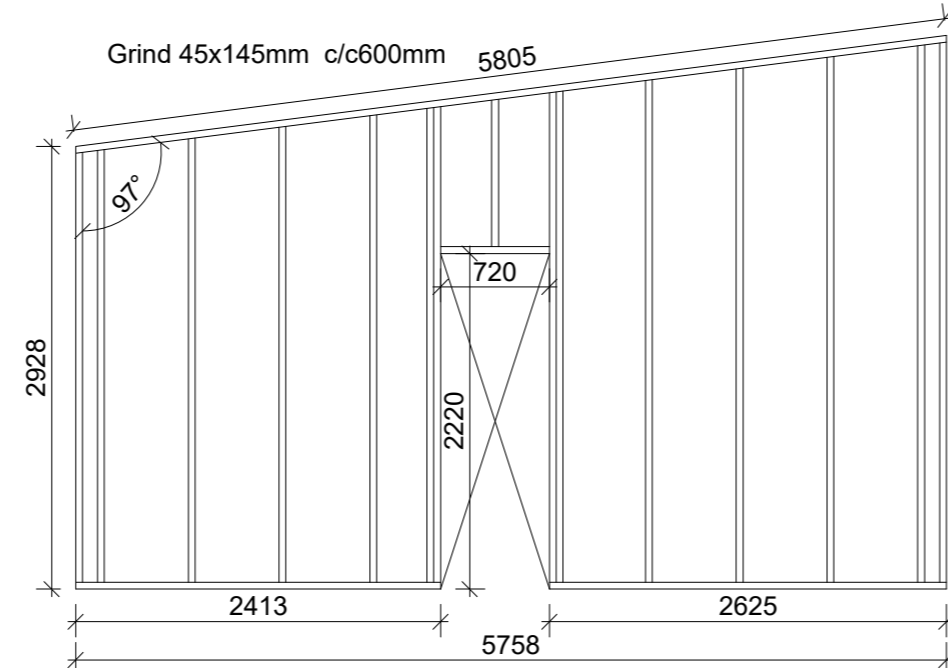
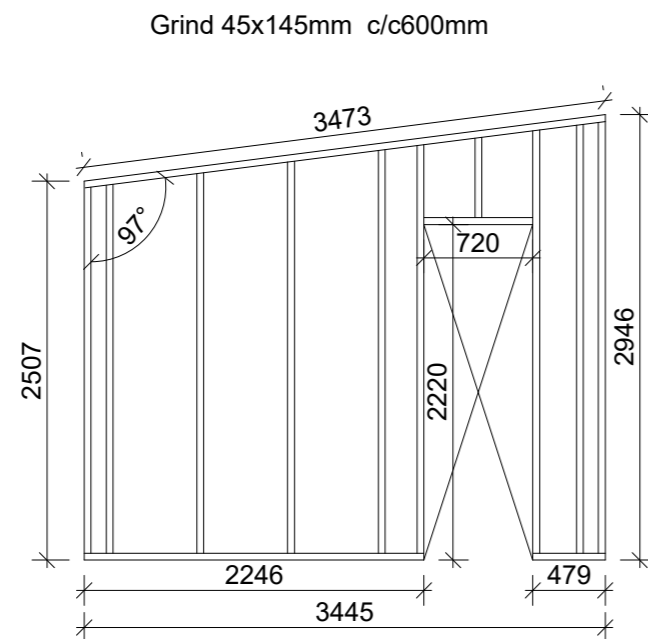
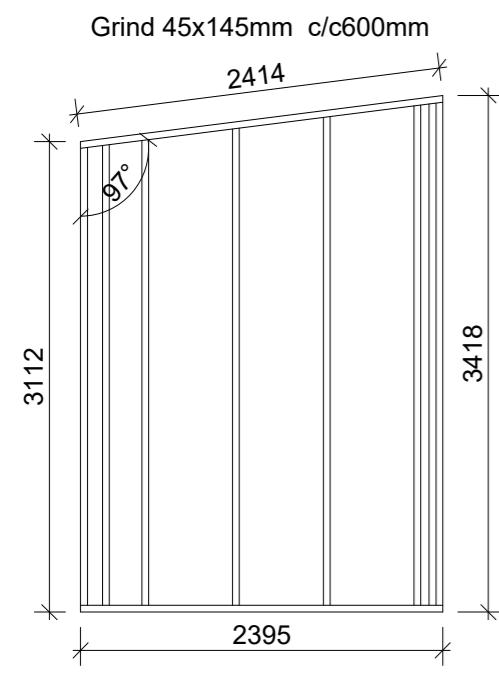
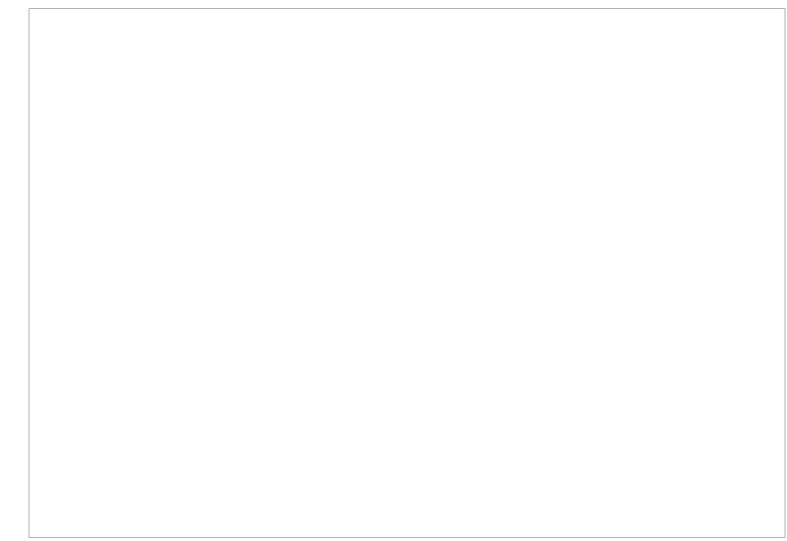
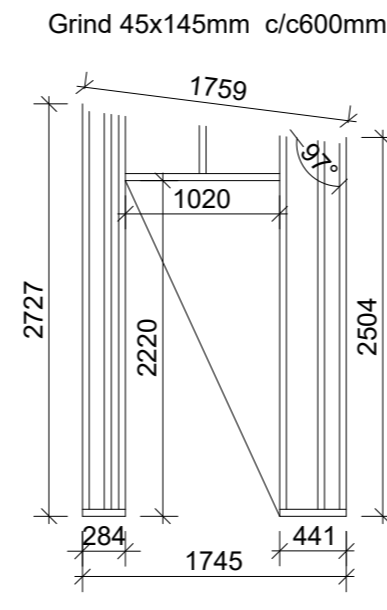
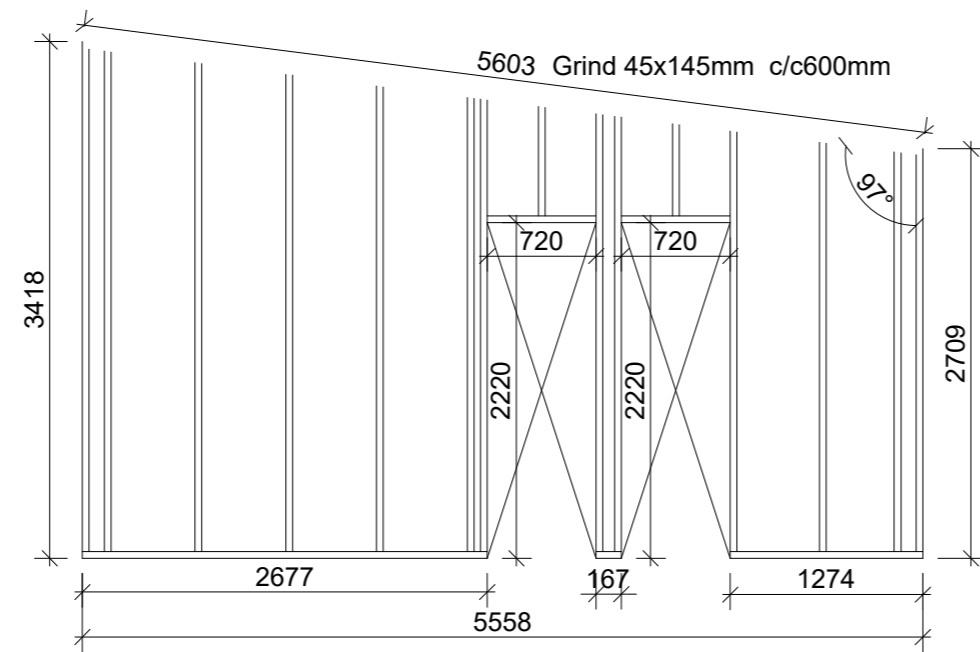
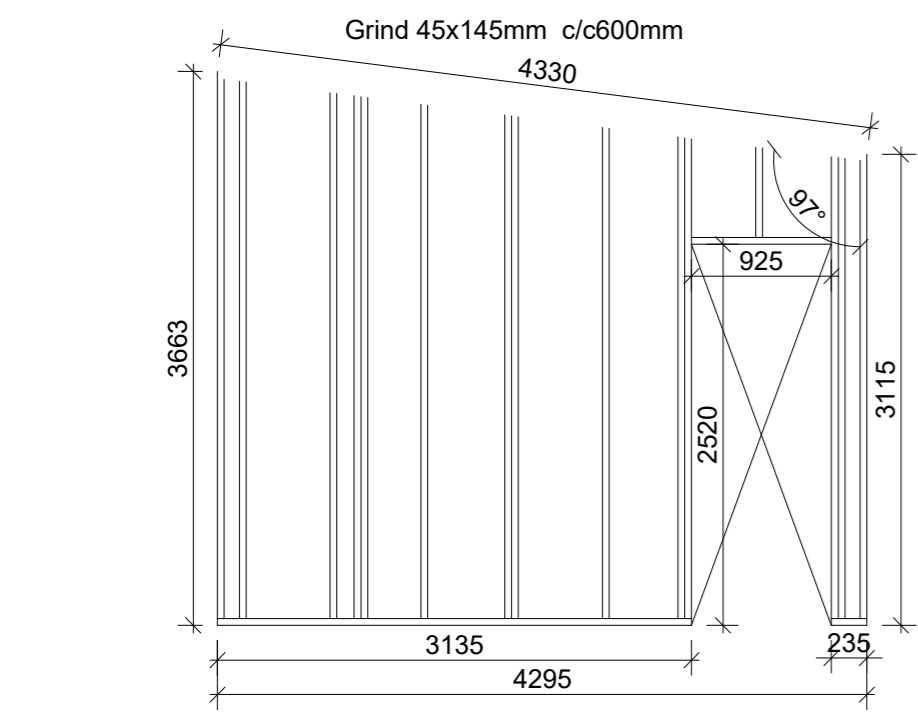

Samþykki arkitekts:

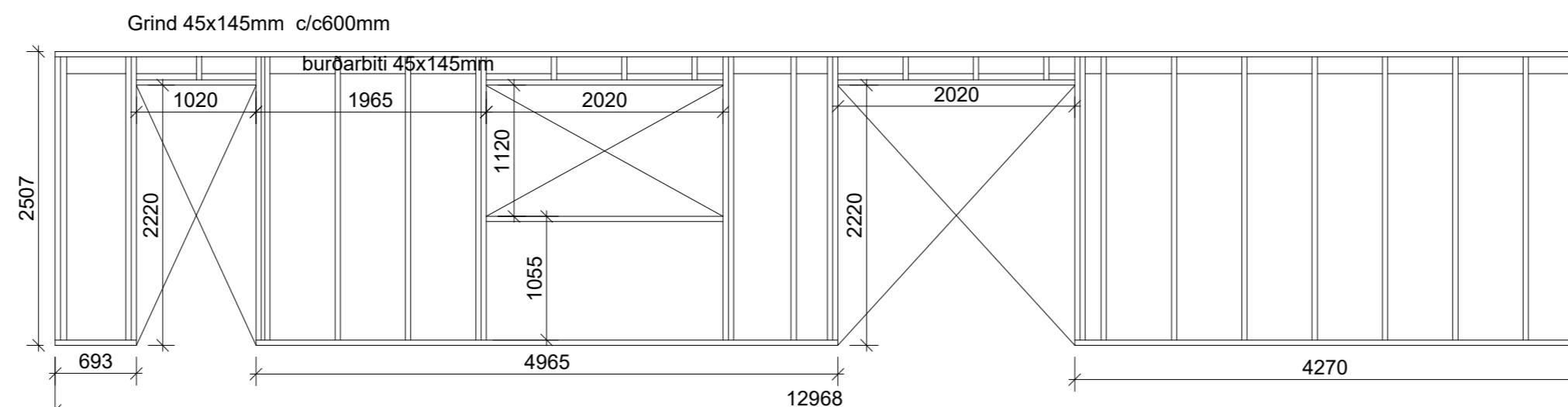
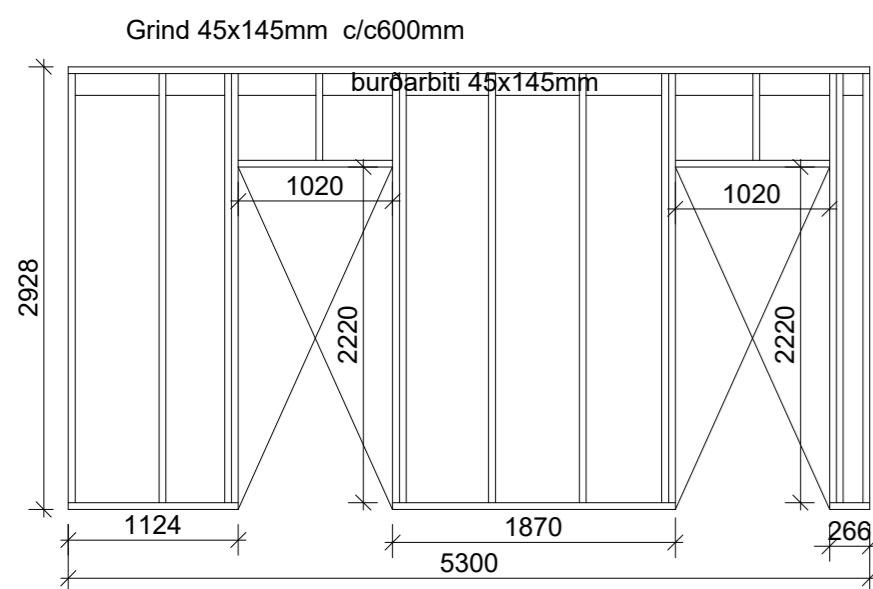

A2

Giljatunga 29 í landi Ásgarðs

Burður
Veggjagrindur

TEIKNINUMER	MÆLIKVARDI	ÚTGÁFA
B-05	1:50	1
Hafsteinn Kr. Halldórsson Byggingatæknifræðingur FTFÍ kt: 120166-3449 hafsteinn.kh@gmail.com	NAFN	DAGSETNING
	hannad	10.08.2022
	teiknad	10.08.2022
	yfirfarid	

SAMP. NR. *Hafsteinn Kr. Halldórsson*

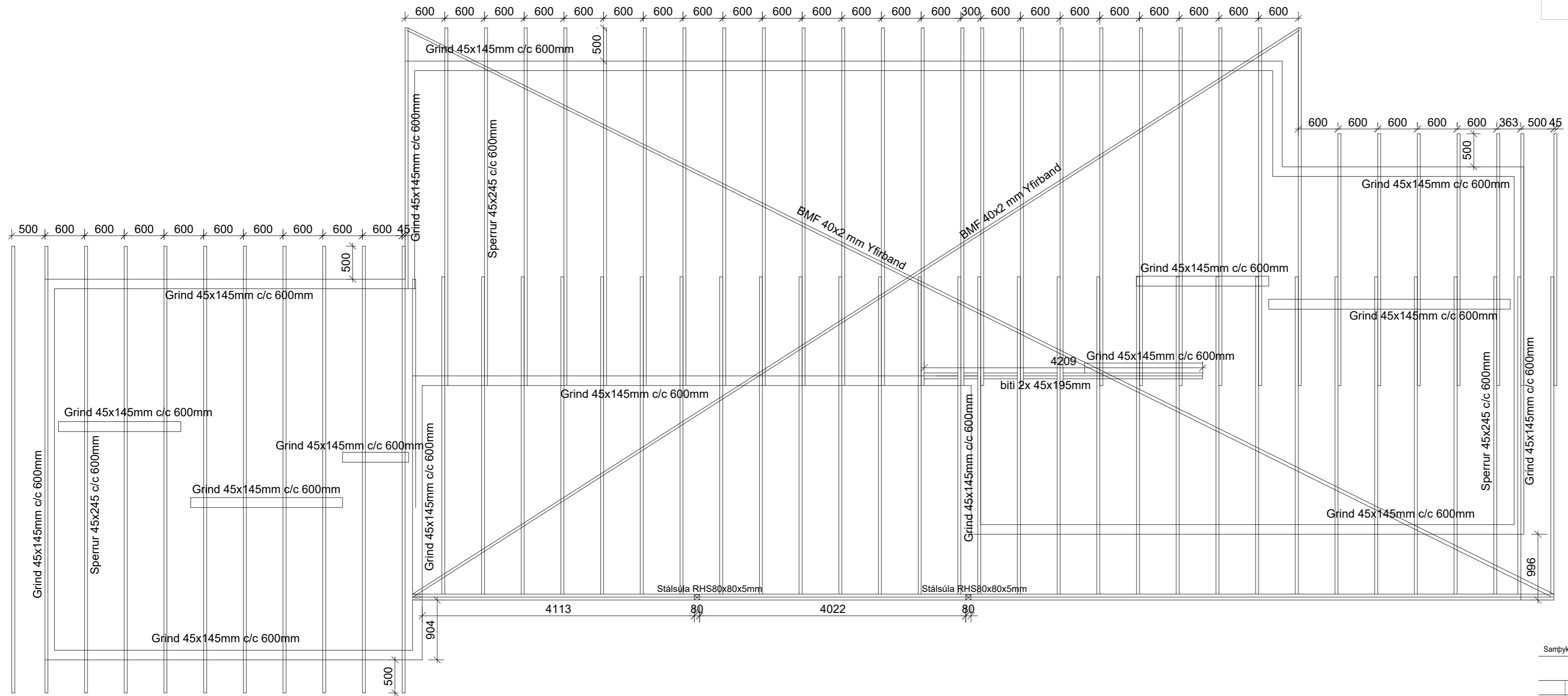

Sperrur og bitar þak 1:50

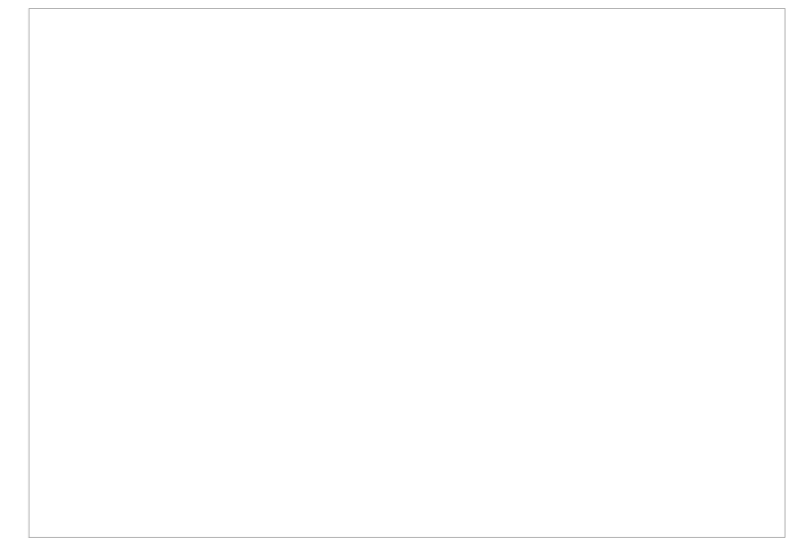

Samþykki arkitekts:

A2

Giljatunga 29 í landi Ásgarðs
Sperrur og bitar þak

TEIKNINÚMÉR	MÆLIKVARDI	ÚTGÁFA
B-06	1:50	1
Hafsteinn Kr. Halldórsson Byggingatæknifræðingur FTFÍ kt: 120166-3449 hafsteinn.kh@gmail.com	NAFN	DAGSETNING
	hannad	10.08.2022
	hakk	10.08.2022
	YFIRFARIÐ	
SAMP. NR.	<i>Hafsteinn Kr. Halldórsson</i>	